

# PROTECTOR P1-P5 MANUAL



[WWW.IWTM-UK.COM](http://WWW.IWTM-UK.COM)  
T: +44 208 255 2903  
E: [INFO@IWTM-UK.COM](mailto:INFO@IWTM-UK.COM)

# TABLE OF CONTENTS

03	DESCRIPTION & FEATURES
06	INSTALLATION
09	DATA & MEASUREMENTS
14	MAINTENANCE
22	ACCESSORIES
23	VALVE KIT
24	SERVICE JOURNAL

# DESCRIPTION & FEATURES

## WHAT IS PROTECTOR P1-P5?

Protector P1-P5 are the smallest models from our IWTM Protector™ range. There are three models, P1, P2 and P5. Each has two distinct separate treatment chambers, designed to remove the system impurities and to engineer the water to keep it in a non-corrosive state.

It provides a “hybrid/multipurpose function” that eliminates the use of chemicals, de-aerators, and magnetic separators.

## NEXT GENERATION OF ELECTROCHEMISTRY

The units provide faster clean-up of old systems and quicker compliance with pre commissioning targets on new systems due to the higher flow rates through the reaction tank (cathode) and the inbuilt strainer basket that enables finer filtration.



Protector P1-P5 is completely insulated and cladded to prevent heat loss and condensation.

P1 can be installed both side stream and full flow. P2-P5 is installed as a side stream device only.

- Protector is an "all in one solution"
- Controls the three key parameters of VDI 2035 ; pH, conductivity & dissolved oxygen
- Creates a hostile environment for bacteria
- Keeps the water clean in closed circulation systems and removes all particles and impurities

## PARTICLE FILTRATION

Protector comes as standard with a robust stainless steel filter, which is 40 micron nominal.

The stainless steel AISI 316 filter, has a large surface which gives a long operating time before cleaning and thus less flushing and refilling.

*Please note: The 40 micron stainless steel filter supplied with the Protector as standard although robust in its manufacturing is a consumable item.*

*It's life expectancy is dependent on the harsh environment it has to deal with when being used to clean existing systems and therefore is not covered by any warranty. On a new system it is possible that the filter can last for many years, but on clean-up project it may only last for a few months.*

# DESCRIPTION & FEATURES

## HOW DOES PROTECTOR P1-P5 WORK?

The system water enters the lower chamber where a dry powerful magnet holds in place any magnetite particles, these will be held in the lower chamber until the Protector is drained or blown down to release and remove them.

After the lower chamber, the water then passes into the upper chamber and is forced through a high grade 40-micron stainless steel filter before going back into the system having been cleaned and treated. The micron filter will capture any non-magnetic particles and prevent them from re-entering the system. These particles will be held in the micron filter and will drop to the lower chamber when the Protector is being blown down to clear the collected debris.

Within the upper chamber and in the middle of the micron filter is where the electrochemistry takes place. The Protector uses pure magnesium bare anodes and with the micron filter basket and tank being connected these two components increase the surface area of the cathode.

This increased surface area of cathode produces a higher rate of electrochemical reaction which results in increased cleaning power and superior performance than other devices.

The bare sacrificial anode consumes the dissolved oxygen by the process of corrosion, the fast corrosion rate of the bare anode quickly releases magnesium hydroxide into the water, and this provides an alkaline pH between 8.2 and 10. The consumption of the dissolved oxygen removes the threat of corrosion from the system water. Compliance with VDI 2035 is still obtained as the anodes sit inside the basket to capture the magnesium residue when the anodes expire.



# DESCRIPTION & FEATURES

## NEODYMIUM MAGNETS

The Protector P1-P5 comes with one dry, powerful magnet. This is mounted on the lower chamber so magnetite is captured and not deposited on the anodes, also preventing the filter basket from clogging up with magnetite.

This provides longer service intervals as well as increased operational life and better function. When the magnets are removed, all magnetite will be released and can be drained out.

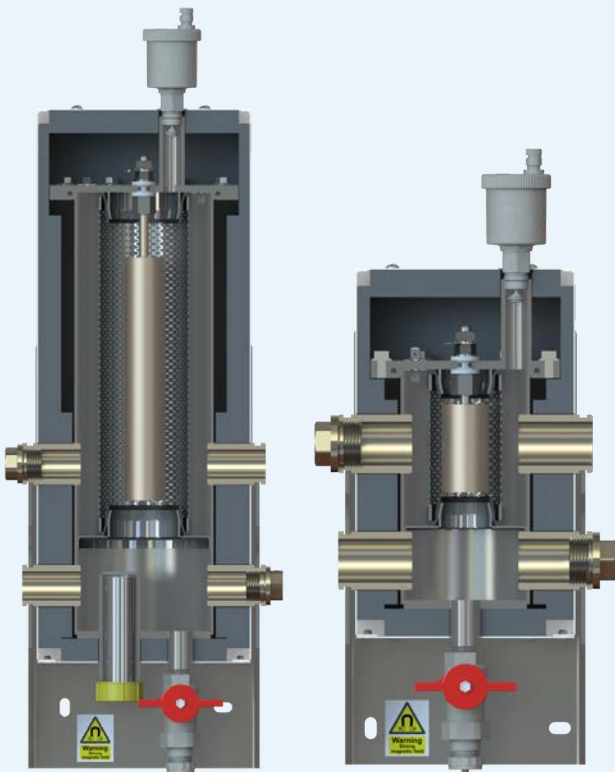

## SACRIFICIAL ANODES

Magnesium anodes provide anodic water treatment and lower the fluid's conductivity.

The anodes also scavenge oxygen and regulate the pH level.

For longer life expectancy, the anodes sit inside a stainless steel filter basket, removing the need for individual anode screens.

## WALL FIXING SYSTEM

Protector P1-P5 has a compact wall fixing system; therefore the unit can be fixed on to the wall to save space in situations where space is important and limited. The system is included as a standard feature in the Protector P1-P5.

The wall fixing bracket is stainless steel, very robust and resistant.

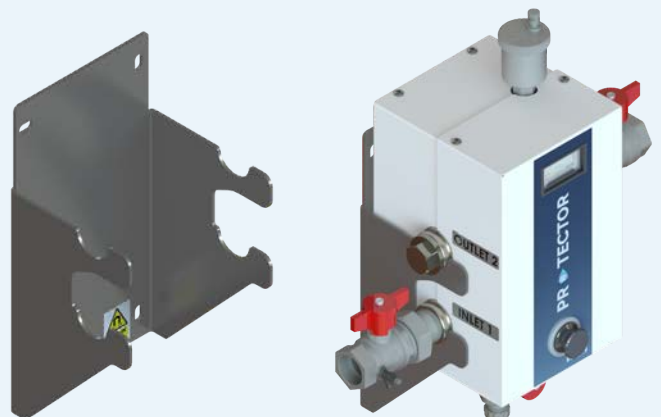

# INSTALLATION

P1 can be installed both side stream and full flow.

P2-P5 is installed as a side stream device only.

## P1 FULL FLOW SCHEMATIC

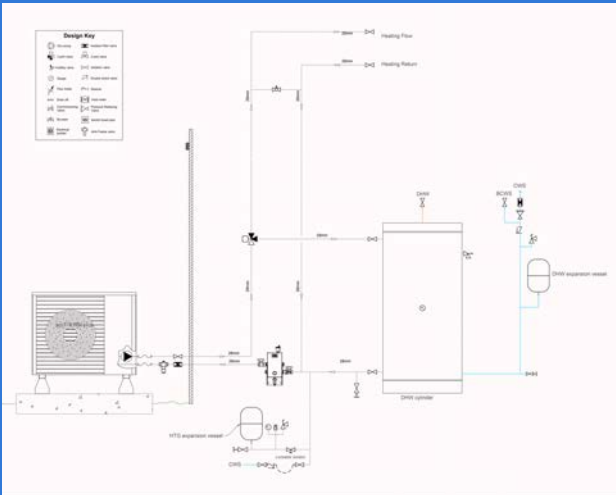

The P1 is ideally suited to ASHP applications as our technology keeps the system clean. ASHP's require clean and air free water, if the water quality is full of air or dirty the ASHP can lock out and result in nuisance shut down.

Also, as ASHP's operate on a lower temperature any % reduction in output due to scaled or blocked pipes can result in the design criteria not being achieved and inconvenience for the homeowner/building operator.

-Pressure side on pump should be to the inlet on Protector P2 + P5 unit.

-Suction side on pump should be to the outlet on the Protector P2 + P5 unit.

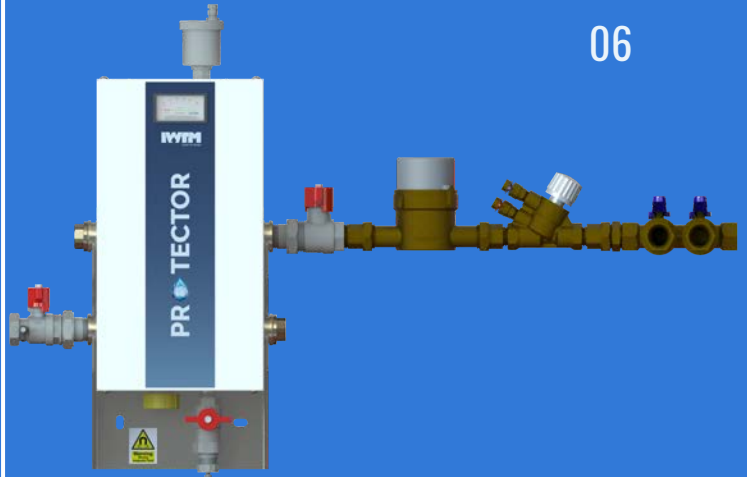

*Shown with UK Installation Kit*

## INSTALLATION CONNECTIONS

### P2 & P5

- 1 x 3/4" Inlet Valve with test point
- 1 x 3/4" Outlet valve
- 2 x 3/4" plugs
- 1 x 3/8" Air Vent
- 1 x 1/2" Drain Valve
- 1 x Water Meter
- 1 x PIC valve with unions
- 1 x flushing bypass
- 1 x 3/4" nipple
- 1 x 3/4" M x 3/4" F swivel union

### P1:

- 1" Inlet Valve with test point
- 1" Outlet valve
- 2 x 1" plugs
- 1 x 3/8" Air Vent
- 1 x 1/2" Drain Valve

**Ensure that 300mm clearance is left above the Protector AAV.**

**Ensure that 600mm clearance is left in front.**

**NOTE: If the top clearance cannot be achieved the Protector can also be removed from the wall bracket for servicing and in this case 100mm above the top of the AAV should be allowed.**

# INSTALLATION

## TYPICAL SIDE STREAM INSTALLATION USING INDIVIDUAL PUMP

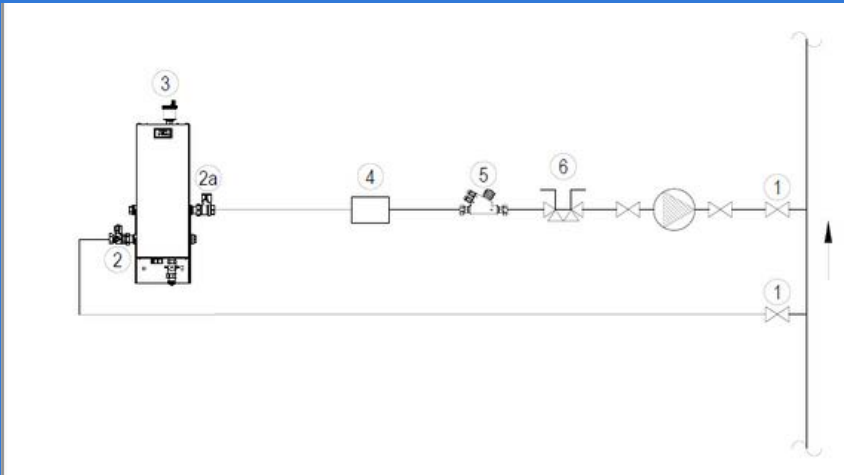

KEY

- 1. CLIENT IV's NOT SUPPLIED
- 2. DRAIN COCK LEVER IV MALE & FEMALE
- 2a. IV MALE & FEMALE
- 3. AIR VENT
- 4. MECHANICAL WATER METER
- 5. PIC Valve
- 6. FLUSHING BY-PASS

## TYPICAL SIDE STREAM INSTALLATION USING SYSTEM PUMP

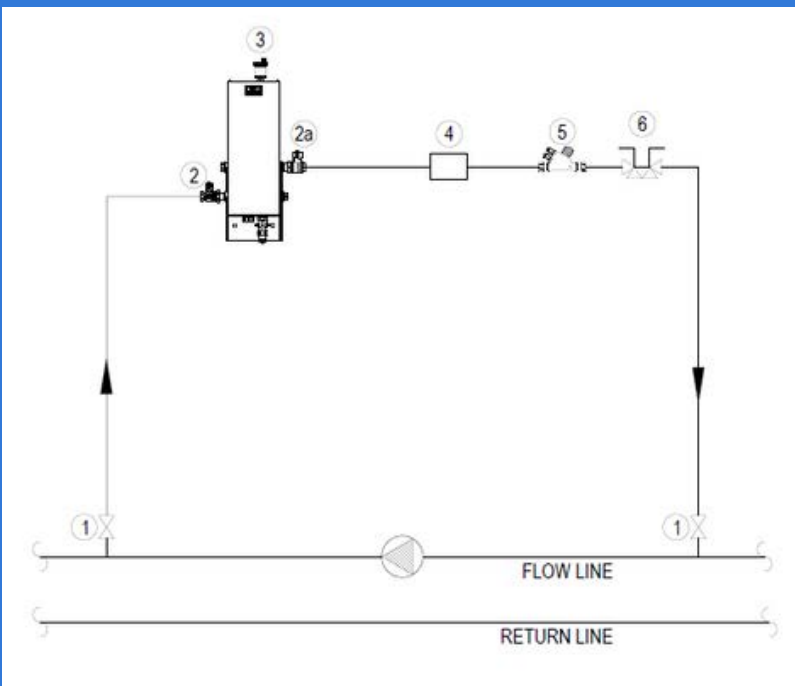

KEY

- 1. CLIENT IV's NOT SUPPLIED
- 2. DRAIN COCK LEVER IV MALE & FEMALE
- 2a. IV MALE & FEMALE
- 3. AIR VENT
- 4. MECHANICAL WATER METER
- 5. PIC Valve
- 6. FLUSHING BY-PASS

# INSTALLATION

## INSTALLATION & COMMISSIONING INSTRUCTIONS - PETTINAROLI VALVE

- Close the outlet valve.
- Keeping outlet closed whilst opening the inlet valve.
- Open the automatic air vent.
- Fill the Protector unit once the automatic air vent has dispensed all of the air.
- Open the outlet valve so water flows through the Protector.
- Check the water meter is rotating.
- Set PIC valve as below:

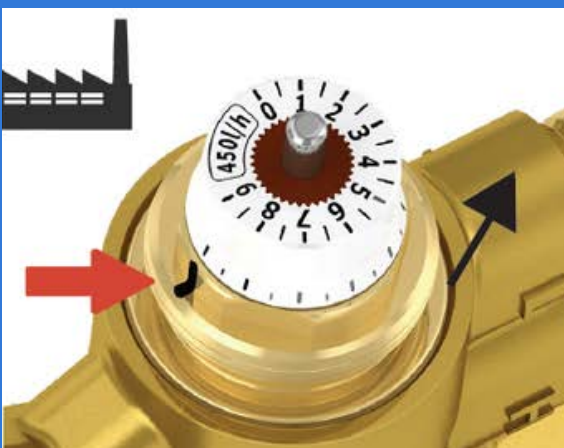

- Remove the handwheel. default setting: position 9



- Turn the selector to the target position to set the flow rate, the settings should be:

Setting 2 for 4 l/min for the P1.

Setting 3 for 5 l/min for the P2.

Setting 5 for 8 l/min for the P5.

Once you have set this up check the flow rate on the water meter corresponds to required settings on the PICV:

by reading the 0.001 cubic meter dial (=1 litre) , which corresponds to litres per minute.

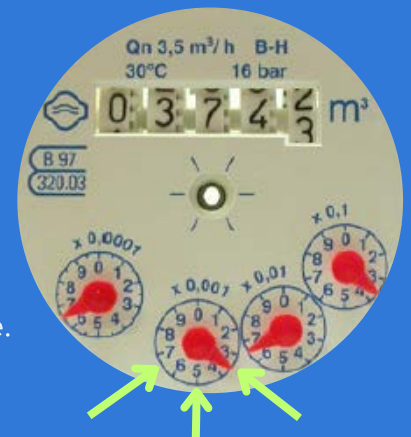

For example it should take 1 minute for the red arrow to read 5 if the setting on the PICV is 3 for 5 litres a minute.



- Re-assemble the handwheel



# DATA & MEASUREMENTS

## PROTECTOR P1-P5 DATA

	LTHW (litres)	Kw	Cooling (litres)	kw	Full flow	Side Stream	Connections	Volume	Max temp	Max Pressure	Design Code
P1	1,000	91	700	47	30 l/min	4 l/min	1"	0.9 L	95	10	PED 2014/68 /EU
P2	2,000	182	1,400	94	NA	5 l/min	3/4"	2 L	95	10	PED 2014/68 /EU
P5	5,000	455	3,500	233	NA	8 l/min	3/4"	3 L	95	10	PED 2014/68 /EU

**Note:** Talk to us for systems that operate at higher pressures or higher temperatures.

### MATERIALS

**Filter House:** Stainless steel AISI 304

**Filter Element:** Stainless steel AISI 316L

**O ring EPDM:** EPDM

**Insulation/Cladding:** PE Foam / Carbon Steel

**Anodes:** Magnesium

**Magnet:** Neodymium

**Surface Finishing:** Powder Coated

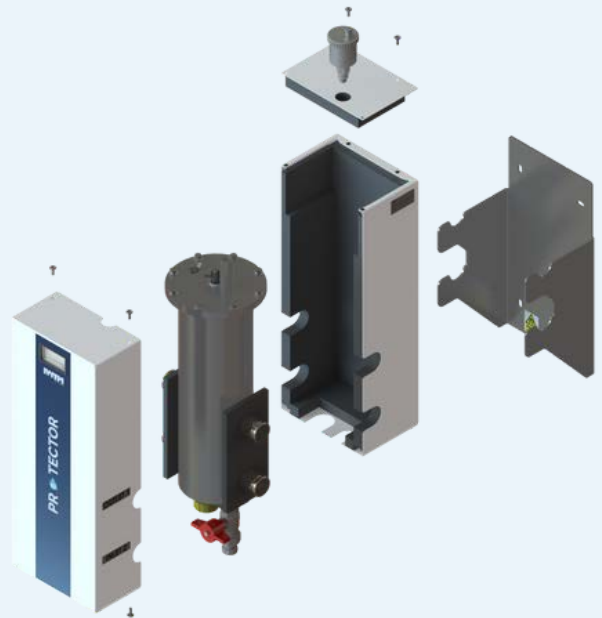

	Dry Weight (Kg)	Full Weight (Kg)	Shipping Weight (Kg)
P1	7.0	7.9	9.5
P2	9.1	11.2	12.3
P5	10.6	13.7	14

# DATA & MEASUREMENTS

## FULL FLOW - PRESSURE DROP

Model	Pstatic (bar)	Flow (l/min)	Pressure Drop (bar)
P1	1	30	0.21
P1	3	30	0.16
P1	5	30	0.12

## SIDE STREAM - PRESSURE DROP

Model	Pstatic (bar)	Flow (l/min)	Pressure Drop (bar)
P1	3	4	0.04
P1	5	4	0.04
P1	10	4	0.04

Model	Pstatic (bar)	Flow (l/min)	Pressure Drop (bar)
P2	3	5	0.03
P2	5	5	0.03
P2	10	5	0.03

Model	Pstatic (bar)	Flow (l/min)	Pressure Drop (bar)
P5	3	8	0.01
P5	5	8	0.02
P5	10	8	0.05

# DATA & MEASUREMENTS

## PROTECTOR P1

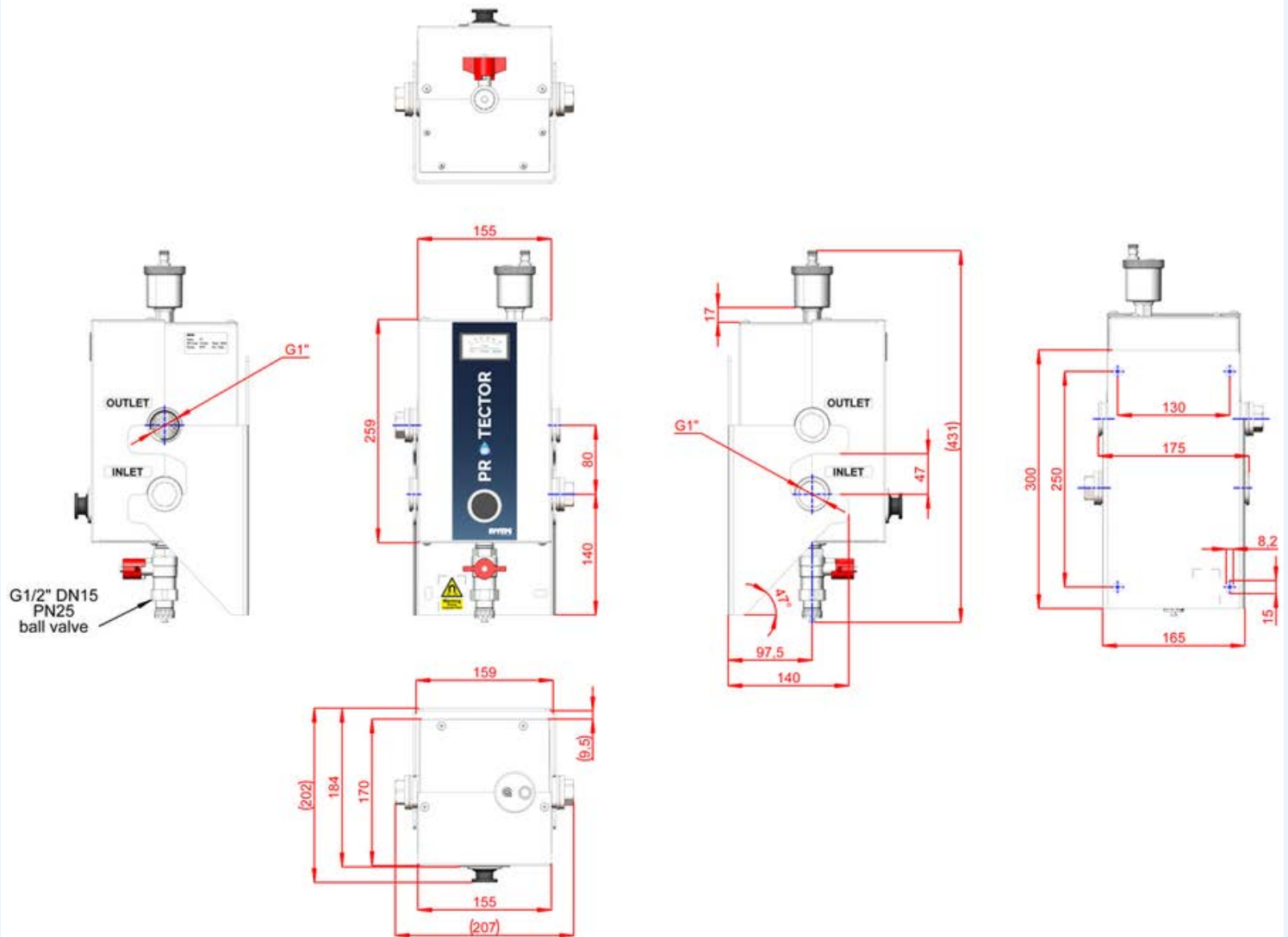

# DATA & MEASUREMENTS

## PROTECTOR P2

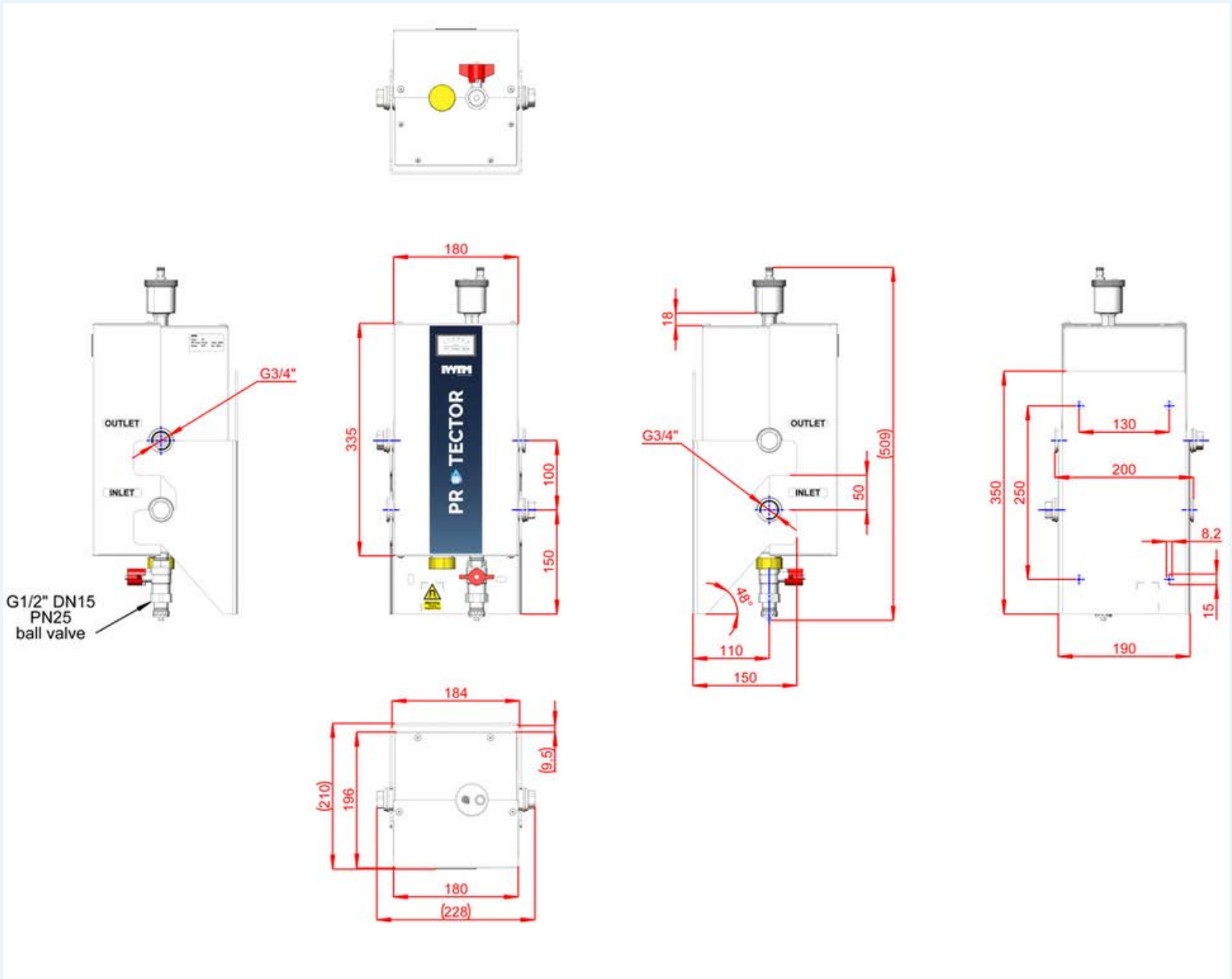

# DATA & MEASUREMENTS

## PROTECTOR P5

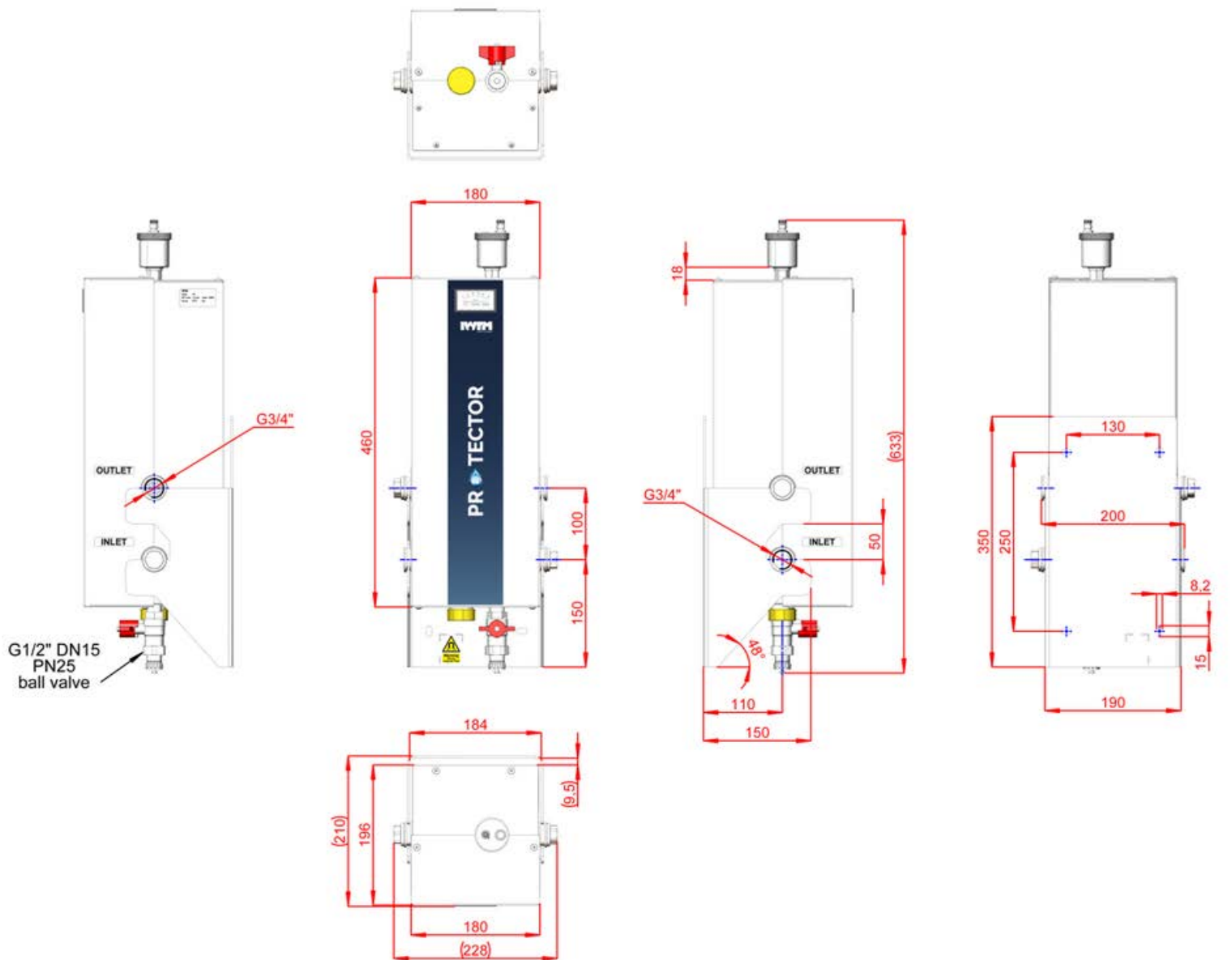

# MAINTENANCE

## MAINTENANCE, CLEANING AND REPLACEMENT OF THE DIAPHRAGM OF PIC VALVE

During valve cleaning operations, use a damp cloth. DO NOT use any detergent or chemical product that may seriously damage or compromise the proper functioning and the reliability of the valve. Maintenance and cleaning of the differential pressure regulator and the control valve must be carried out as per following instructions, after isolating and draining.



Step 1a: completely remove the knob



Step 2: using a 21mm spanner unscrew the headwork.



Step 3: remove the headwork.



Step 4: push down the control valve stem and pull the diaphragm out



Step 5: clean the diaphragm with water and a cloth

# MAINTENANCE

## MAINTENANCE, CLEANING AND REPLACEMENT OF THE DIAPHRAGM OF PICV VALVE



Step 6: put back the diaphragm. Push it in its seat



Step 7: replace the headwork



Step 8: screw the headwork with 20 Nm torque



Step 9: replace the handwheel.

# MAINTENANCE

## DRAINING & BACKWASHING THE FILTER

The Protector unit needs to be drained frequently ; how often is dependent on the water quality.

The higher the starting conductivity level, the more sludge there'll be, resulting in a need for more frequent draining.

This is to flush out the sludge and particles that have been collected in the bottom of the tank, from the magnet trap and the strainer.

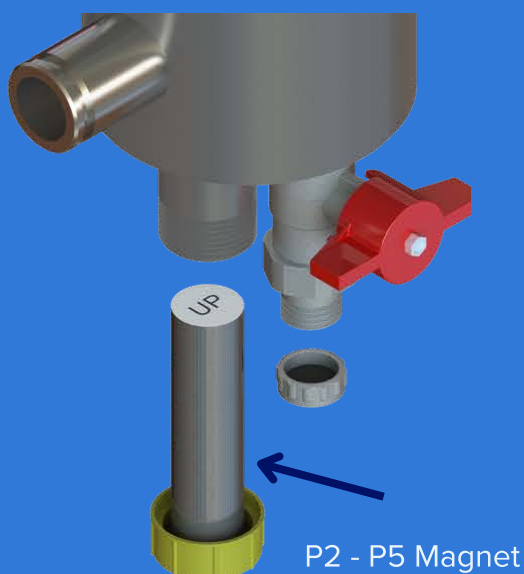

P1 Magnet

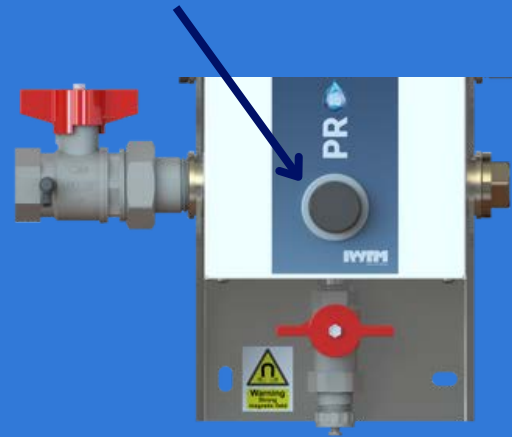

The magnet in the Protector comes as one magnet. The magnet is underneath the Protector within a screwed cap, for the P2 and P5. For the P1 it is a surface mounted magnet on the front of the unit.

- Close the inlet to the Protector.
- Remove the magnet from underneath or the front.
- Open the drain valve on the bottom of tank and flush until the water is running clear of debris.
- When complete, close the drain valve and replace the magnet.



# MAINTENANCE

## ANALOGUE GALVANOMETER

The analogue galvanometer shows the galvanic current in milliamps between the anodes and the cathode (the tank body), with the system water being the medium.

The analogue galvanometer is always in a continuous reading position.

Pure water is non conducting, therefore the more impurities and oxygen in the water the more current will flow between the anode and the cathode.

When the water quality improves, the current diminishes and may measure even as low as 0.2 to 0.3 milliamps when the system water is fully passive.

The Protector system is self-regulating, the anode automatically works harder with corrosive water than with water that is no longer reactive.

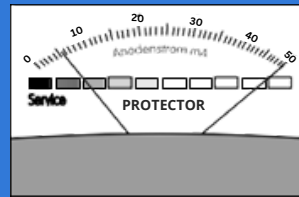

The needle swing lies between 10% and 100%.

This is the normal operating region. The lower the reading, the less the anode needs to work, and the less impurities are in the system water.

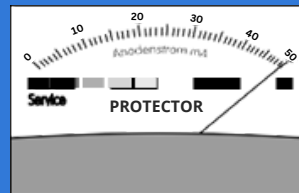

The needle always reads 100%.

The anode is working hard.

If the needle remains in this position for longer than one heating season, the Protector may be undersized for the system.

Action: check the system volume

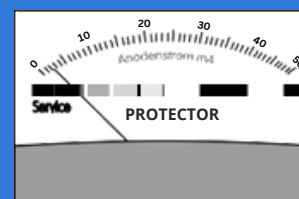

The needle lies continuously close to the red region ;

the needle still drops

to the minimum reading when you press the test button however, the anode no longer needs to work because the chemical reactions in the water have finished, or the anode can no longer work because it is coated in a barrier layer...

# MAINTENANCE

## ANALOGUE GALVANOMETER & PUSH BUTTON

Action: remove the sludge from the Protector and fill with fresh water.

Keep the isolation valves closed for a day to hold the more corrosive fresh water inside the Protector.

After a day, if the operating meter shows a higher reading, everything is operating correctly, and the Protector can be put back into operation. Otherwise, you need to open the lid to inspect the appliance.

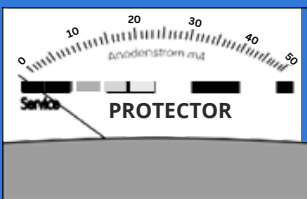

**The needle drops into the red region within a few weeks.**

The anode is spent or coated in a barrier layer or the Protector is isolated from the system and no water is circulating through it.

Action: check circulation or open the appliance and clean or replace the anodes.

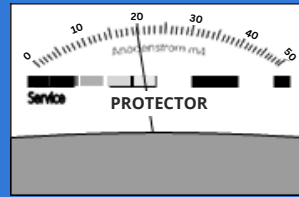

**The meter continues to show a constant reading over a long period.**

The operating meter might be faulty.

Action: Disconnect one wire from the anode holder and the needle should drop to the left.

**If there is no change in the needle position, the meter is probably faulty.**

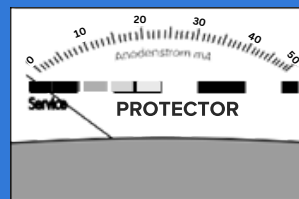

**After servicing, if the indicator position is hard left in the red.**

If the anode wires are connected wrong, it will create a short circuit and the swing meter will sit in the red zone – to correct this change the two connection wires around on the anode and the earth.

While the Protector is increasing the pH and scavenging oxygen the water gets less aggressive and the current will decrease and stabilise. (normally from 4-15 mA). If some chlorides or sulphates should interfere, resulting in higher conductivity or increased oxygen (feed water), the ampere & output will increase again.

# MAINTENANCE

## MAGNESIUM ANODES

The filter anode is in a basket of stainless steel wire mesh called the ss micron filter and does not normally need any cleaning.

If however, its coated in slime from chemical residue or any other debris, this can be removed with a suitable scraper to get back to the bare anode surface. Check the anode for proper functioning (mA instrument).



## TOOLS:

- Isolating nut dry side 13 mm spanner
- Isolating bolt wet side 13 mm spanner
- Flange cover nuts 10 mm spanner
- Phillip screwdriver

## SERVICE

Service on the Protector unit should be done once a year. However, this is also depending upon the quality of the system water.

If there has been an existing problem with sludge, sediments etc. before the Protector installation, we recommend a first service after 3 months of operation. It's also important to take a water sample out of the system, for analysis in a laboratory.

The isolation screw going through the flange has two nylon washers one on each side of the flange. Once opened, they **cannot** be reused. These washers are not part of the replacement kit. So please do not undo the isolation screw.

Make sure not to rotate the bolt while changing the anode. Use a 13mm spanner to hold the isolation bolt securely whilst removing/fitting the anode. This will ensure the isolation screw does not turn. Once the anode has been replaced, use a test meter to check there is no continuity between the anode & the flange.

The two isolation washers have two functions

1. To create a watertight seal
2. To electrically isolate the anode from the tank.



# MAINTENANCE

## SERVICE

- Close the inlet and outlet ball valves.
- Remove the front and top case assembly
- Unscrew the air vent and empty the tank through the drain valve.
- Unbolt the flange lid.
- Disconnect the galvanometer cables.
- Carefully lift up the lid, the anode is attached to the underside.
- Check the anode.
- Clean the anode, if the magnesium is below 10mm diameter, replace with a new one.
- Take out the strainer and flush / clean.
- Clean the tank inside using a hose or a pressure gun.
- Check all parts belonging to the Protector and clean them if required. (AAV, PICV, water meter, etc.)

When replacing the anode hold the isolation screw going through the flange and unscrew the anode. After mounting a new anode, make sure that all screws are tight and that the electrical wiring is properly reinstalled. If there's no indication on the meter, the Protector is not working, so please check the wiring is correct.

TORQUE settings

Insulation bolt 25Nm

Flange 14 Nm

When done, put everything back in place and fill up the Protector on the inlet.

When the air vent stops letting out air, the tank is refilled and you can open the outlet and start the circulation again.

Check that the water meter is running, on a side stream installation.



# MAINTENANCE

## PARTICLE FILTER

Inside the Protector unit there is a ss micron filter, to catch and remove all sediments and particles.

- Twist the filter slightly to lift it out.
- Clean the filter with a water hose.
- Make sure all particles are removed from the filter.

When done put it back by turning it slightly, making sure it is fully seated.

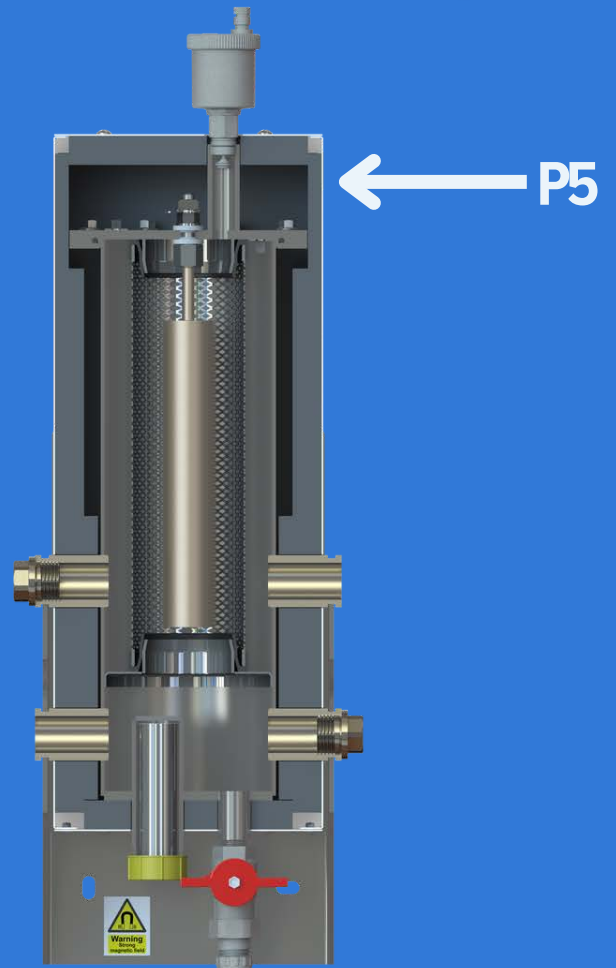
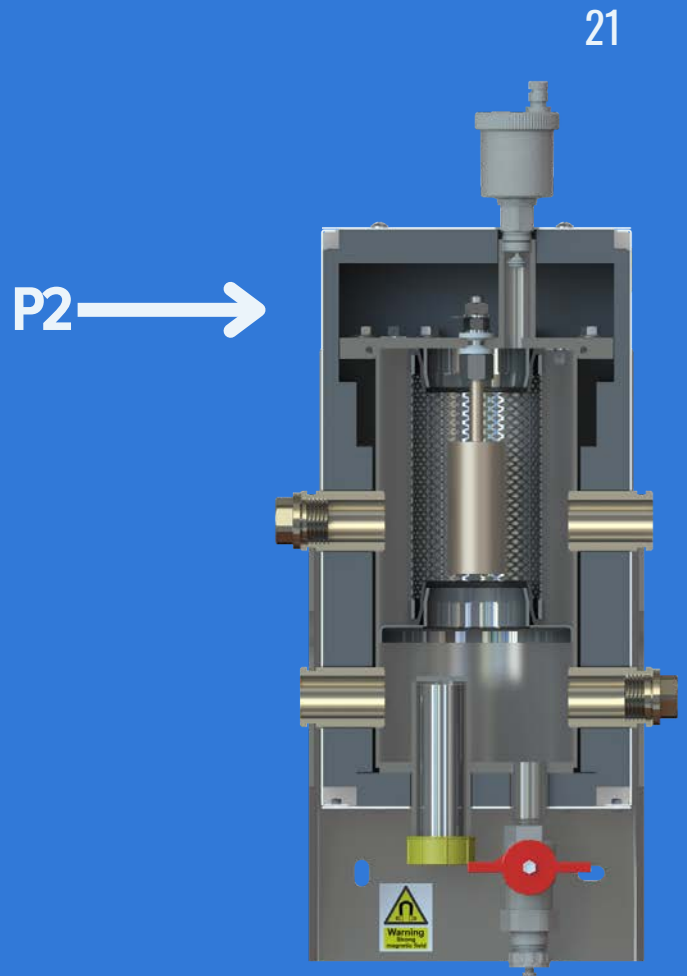
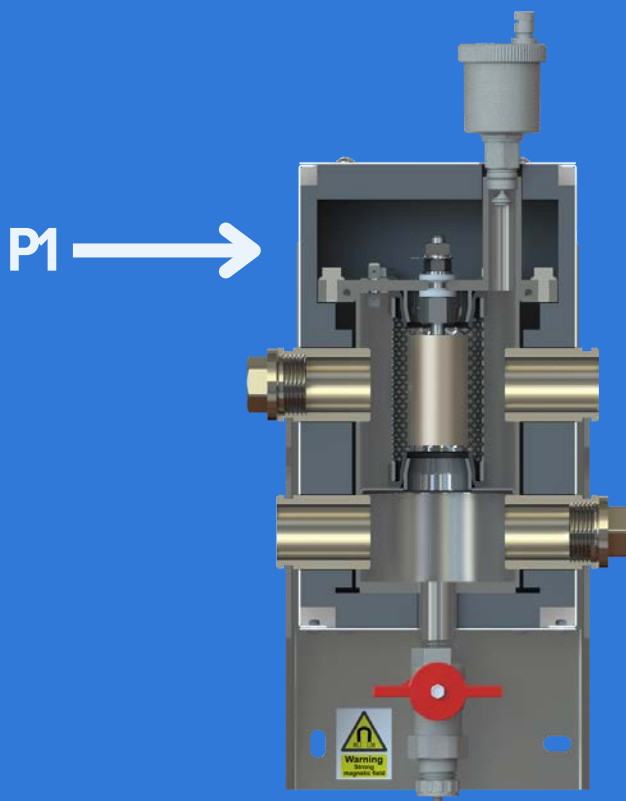

# ACCESSORIES

Part No.	Description
<b>Protector - Complete Units</b>	
101469	PROTECTOR P1
101470	PROTECTOR P2 ANALOG 1" F WITH UK VALVE KIT
101471	PROTECTOR P5 ANALOG 1" F WITH UK VALVE KIT
<b>Protector - Stainless Steel Strainers</b>	
F_00026	2LAY INOX FILTERKIT SIZE P1, 40µm
F_00027	2LAY INOX FILTERKIT SIZE P2, 40µm
F_00028	2LAY INOX FILTERKIT SIZE P5, 40µm
<b>Protector - Spare Parts</b>	
F_00015	AIR VENT
F_00004	GALVANOMETER
F_00030	P1 FLANGE O RING
F_00029	P2 / P5 FLANGE O RING
VKP1001	P1 SIDE STREAM VALVE KIT
F_00001	P1 ANODE
F_00003	P2 ANODE
F_00002	P5 ANODE
P2-01-02-04_KIT	ANODE ISOLATION BOLT

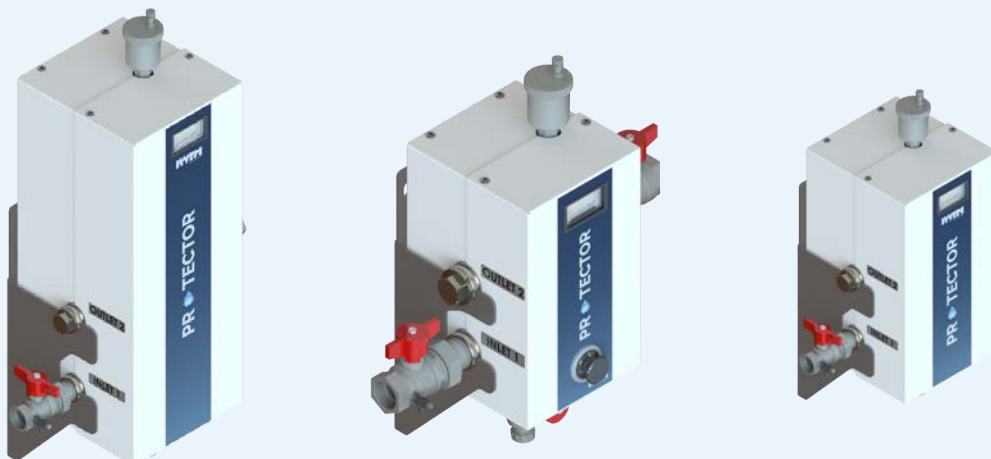

# VALVE KIT

The UK Protector P2 - P5 is supplied with the following valve kit which is packed inside the main Protector box. There is an optional valve kit for the P1, when used on side stream applications.

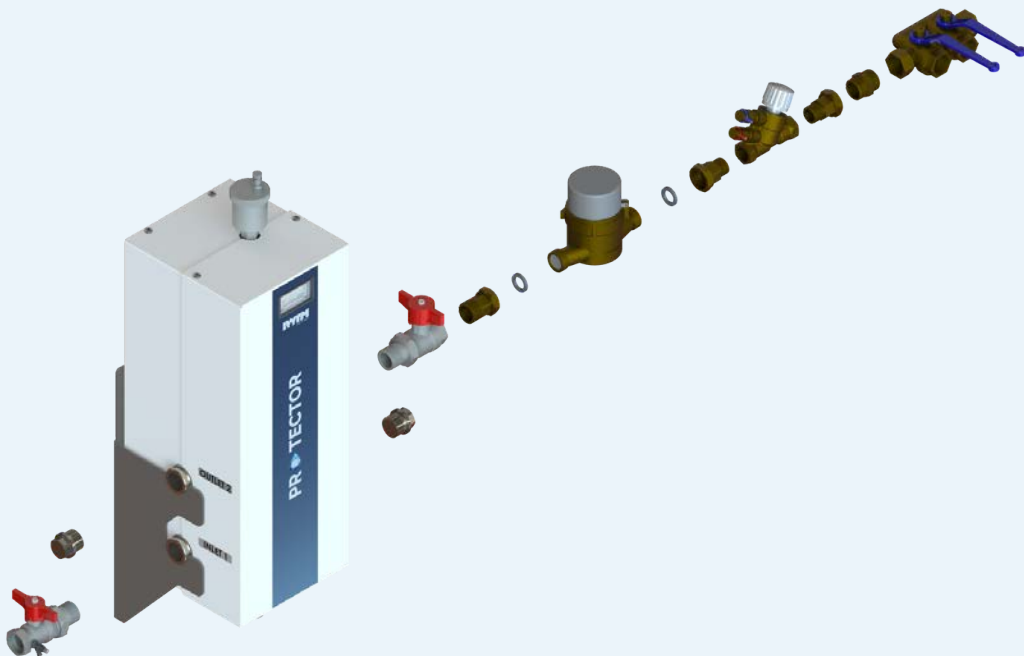
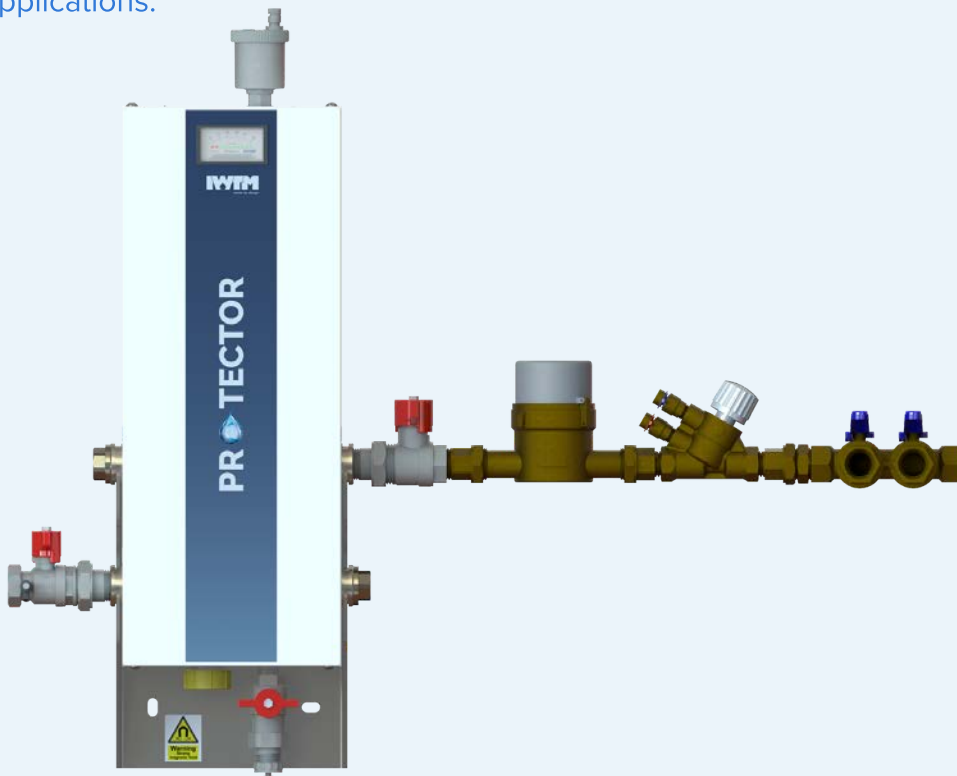







Founded in 1992, IWTM have been working with chemical free water treatment using electrochemistry for over 30 years and have offices in Norway, UK, Finland, Sweden, Canada, USA and a worldwide presence in the Marine sector.

We have developed models specifically suited to the higher demands of the marine industry operating at higher pressures and higher temperatures. The marine products are provided worldwide on the world's largest cruise ships working with the leading operators in this sector.

Having secured DNV approval in 2003, we are still the only chemical free water treatment manufacturer to have this certification and approval. DNV is a globally leading quality assurance and risk management company operating in more than 100 countries.

The IWTM Protector™ is our most recently developed product. The Protector range is now available to our land-based customers.

Version 1: October 2023

*In line with continued product development we reserve the right to make any changes to this document without any given notice.*

# PROTECTOR

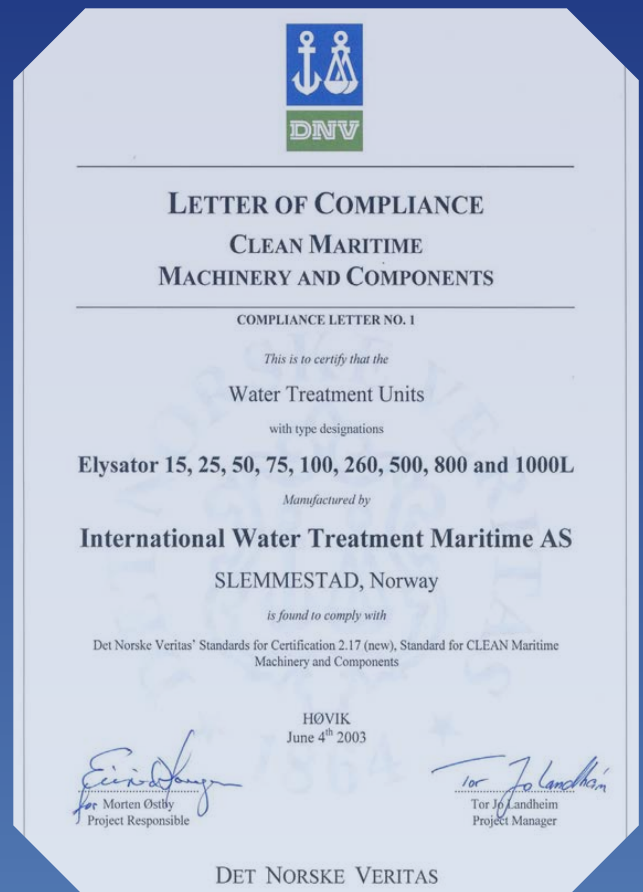

SUTTON BUSINESS CENTRE  
RESTMOR WAY  
WALLINGTON SM6 7AH

WWW.IWTM-UK.COM  
T: +44 208 255 2903  
E: INFO@IWTM-UK.COM