

PROTECTOR PO.5F MANUAL

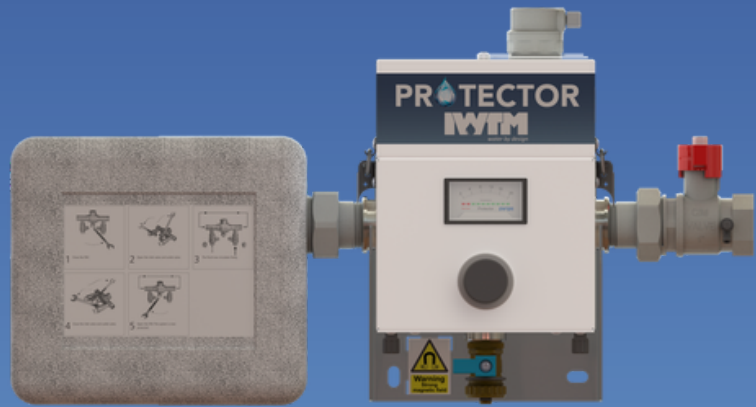

WWW.IWTM-UK.COM
T: +44 208 255 2903
E: INFO@IWTM-UK.COM

TABLE OF CONTENTS

03	DESCRIPTION & FEATURES
07	INSTALLATION
10	DATA & MEASUREMENTS
13	MAINTENANCE
17	FILTER BY-PASS INSTRUCTION
18	ACCESSORIES
19	VALVE KIT
20	WARRANTY CONDITIONS
21	SERVICE JOURNAL

DESCRIPTION & FEATURES

WHAT IS PROTECTOR P0.5F?

Protector P0.5F is the smallest model from our IWTM Protector® range. Designed to remove the system impurities and to engineer the water to keep it in a non-corrosive state.

It provides a “hybrid/multipurpose function” that eliminates the use of chemicals, de-aerators, and magnetic separators.



ASHP CHEMICAL FREE WATER TREATMENT USING THE IWTM-UK P0.5F

The P0.5F is supplied as a kit with a filling and rinsing station with additional filtration to protect the ASHP and ensures that water quality compliance with UK Guidance TM20 and the German Standard VDI 2035 is achieved.

The P0.5F is designed to maintain TM20 and VDI 2035 water standards and the system water quality should be at these levels at the time of the initial installation of the P0.5F and ASHP.

Existing chemicals and system debris should be removed from the system and systems should be resin rinsed as required to meet these standards. This ensures compliance with Part L of the Building Regulations that states whenever you install a new heating appliance to an old system the system should be thoroughly cleaned before the system water is introduced to the new appliance.

DESCRIPTION & FEATURES

NEXT GENERATION OF ELECTROCHEMISTRY

- Protector P0.5F is completely insulated and cladded to prevent heat loss and condensation.
- P0.5F is installed full flow.
- Protector is an "all in one solution"
- Controls the three key parameters of VDI 2035 ; pH, conductivity & dissolved oxygen
- Creates a hostile environment for bacteria
- Keeps the water clean in closed circulation systems and removes all particles and impurities
- The P0.5F is bi-directional. The inlet test point isolation valve can either be on the left or the right depending on the flow direction.
- The by-pass filter valve is always installed upright on the P0.5F outlet.

PARTICLE FILTRATION

Protector comes as standard with a robust external stainless steel filter as part of the by pass valve arrangement.

The stainless steel AISI 316 filter, has a large surface which gives a long operating time before cleaning and thus less flushing and refilling.

Please note: The external stainless steel filter supplied with the Protector as standard although robust in its manufacturing is a consumable item.

It's life expectancy is dependent on the harsh environment it has to deal with when being used to clean existing systems and therefore is not covered by any warranty. On a new system it is possible that the filter can last for many years, but on clean-up project it may only last for a few months.

DESCRIPTION & FEATURES

HOW DOES PROTECTOR P0.5F WORK?

The system water enters the chamber where a dry powerful magnet holds in place any magnetite particles, these will be held in the chamber until the Protector is drained or blown down to release and remove them.

Within the chamber is where the electrochemistry takes place. The Protector uses a pure magnesium anode.

The sacrificial anode consumes the dissolved oxygen by the process of corrosion, the fast corrosion rate of the anode quickly releases magnesium hydroxide into the water, and this provides an alkaline pH between 8.2 and 10. The consumption of the dissolved oxygen removes the threat of corrosion from the system water. Compliance with VDI 2035 and TM20 is obtained as the anode is encapsulated within the mesh, to capture the magnesium residue when the anode expires.

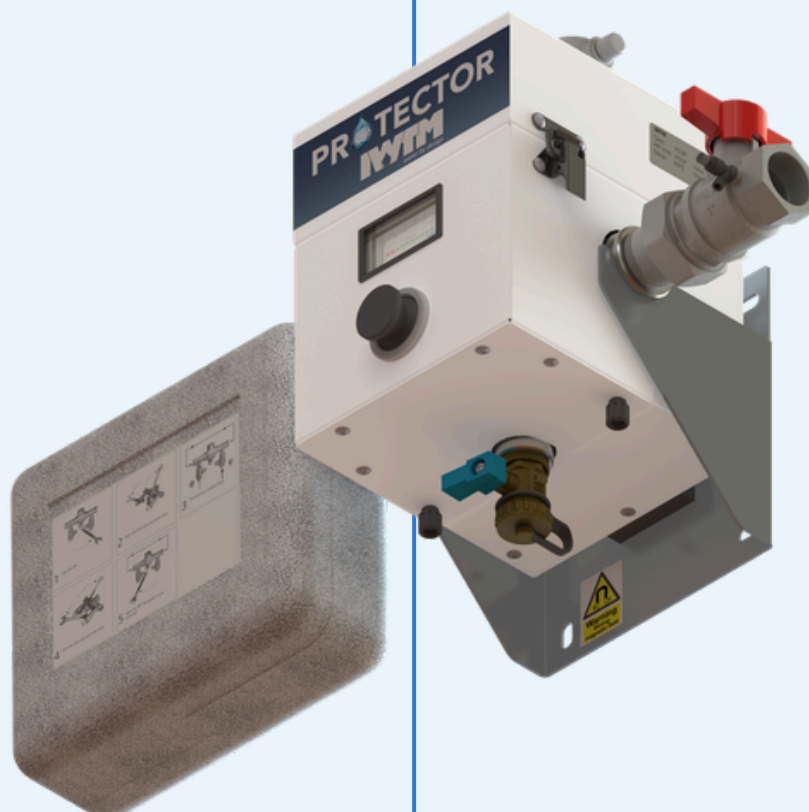

DESCRIPTION & FEATURES

NEODYMIUM MAGNET

The Protector P0.5F comes with one dry, powerful magnet. This is mounted on the chamber so magnetite is captured and not deposited on the anode, also preventing the external filter basket from clogging up with magnetite.

This provides longer service intervals as well as increased operational life and better function. When the magnet is removed, all magnetite will be released and can be drained out after closing off the outlet valve and opening the drain.

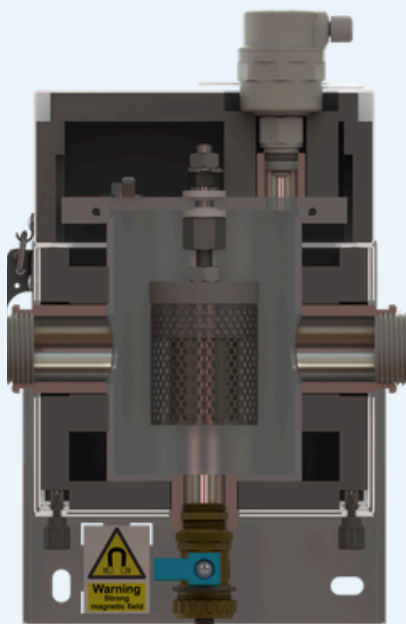

SACRIFICIAL ANODES

Magnesium anodes provide anodic water treatment and lower the fluid's conductivity. The anodes also scavenge oxygen and regulate the pH level.

For longer life expectancy, the anode sits inside a stainless steel filter basket, removing the need for an individual anode screen.

WALL FIXING SYSTEM

Protector P0.5F has a compact wall fixing system; therefore the unit can be fixed on to the wall to save space in situations where space is important and limited. The system is included as a standard feature in the Protector 0.5F

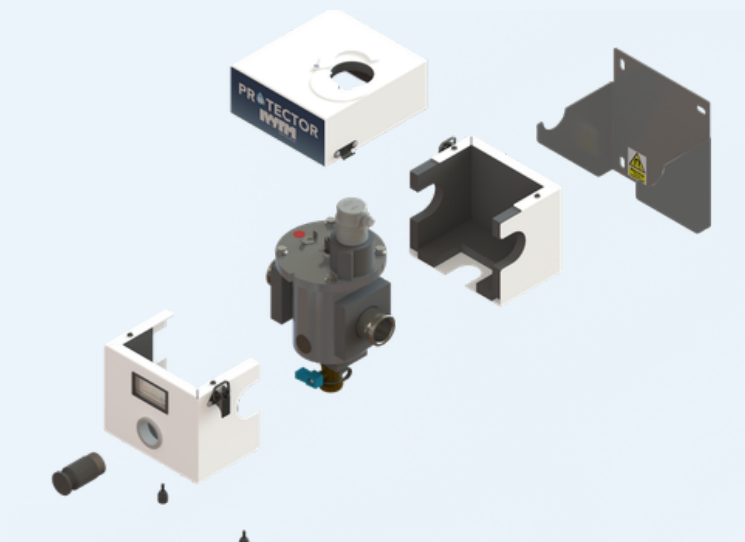

INSTALLATION

INSTALLATION OF THE P0.5F TO A DOMESTIC SYSTEM STEP BY STEP GUIDE

Drain the system if required and install the Protector P0.5F



Fill the system using an IWTM filling / demineralised device, vent and circulate and run the system to remove the air.



Connect a ProFill Prime to rinse the system. This will remove any remaining chemicals on existing systems and installation debris from new systems. Rinse the system until the conductivity is as close to zero as possible and the system water is clear.



Any minor remaining cleaning of the system will be completed by the Protector.



Clean out the Protector as part of the ongoing service regime and test the water quality. The pH should be between 8.2 - 10 with a conductivity of <math><100\text{ us /cm}</math>.



Maintain anode. Advise the customer regarding the monitoring of the galvanometer swing meter.



Any future topping up should be made using a suitable ProFill device. It is important to apply warning notices to the system and to provide information in the homeowner pack regarding the importance of topping up with demineralised water.

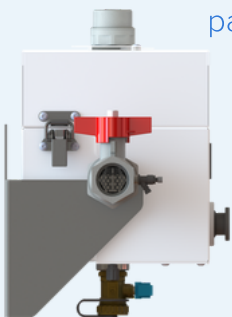

←
FLOW

INSTALLATION

P0.5F FULL FLOW SCHEMATIC

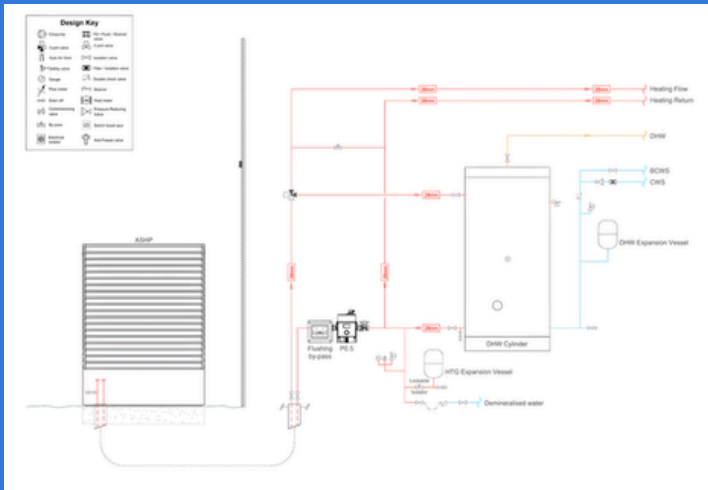

The P0.5F is ideally suited to ASHP applications as our technology keeps the system clean. ASHP's require clean and air free water, if the water quality is full of air or dirty the ASHP can lock out and result in nuisance shut down.

As ASHP's operate on a lower temperature any % reduction in output due to scaled or blocked pipes can result in the design criteria not being achieved and inconvenience for the homeowner/building operator.

08

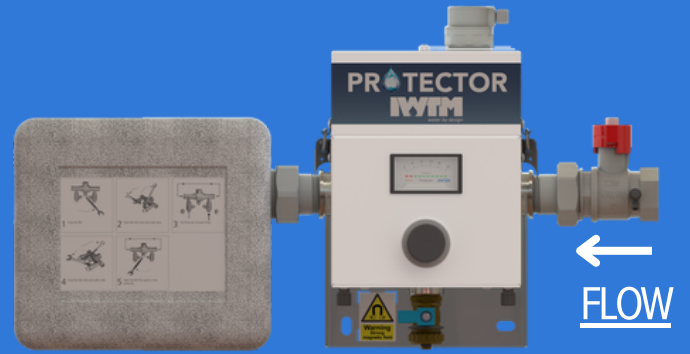

The filter bypass valve should be installed upright as shown.

INSTALLATION CONNECTIONS

P0.5F

- 1" Inlet Valve with test point
- 1" Outlet union
- 2 x 1" M x F stainless steel elbows, for change of direction if needed
- 1 x 1" Bypass/ Filling Filter Valve Assembly
- 1 x 3/8" Air Vent
- 1 x 1/2" Drain Valve

Ensure that 300mm clearance is left above the Protector AAV.

Ensure that 600mm clearance is left in front.

NOTE: *If the top clearance cannot be achieved the Protector can also be removed from the wall bracket for servicing and in this case 100mm above the top of the AAV should be allowed.*

DATA & MEASUREMENTS

PROTECTOR P0.5F DATA

	LTHW (litres)	Kw	Cooling (litres)	kw	Full flow	Connections	Volume	Max temp	Max Pressure	Design Code
P0.5F	500	45	325	25	30 l/min	1"	0.65L	95°C	4 Bar	PED 2014/68/EU

MATERIALS

Filter House: Stainless steel AISI 304

Filter Element: Stainless steel AISI 316L

O ring EPDM: EPDM

Insulation/Cladding: PE Foam / Carbon Steel

Anodes: Magnesium

Magnet: Neodymium

Surface Finishing: Powder Coated

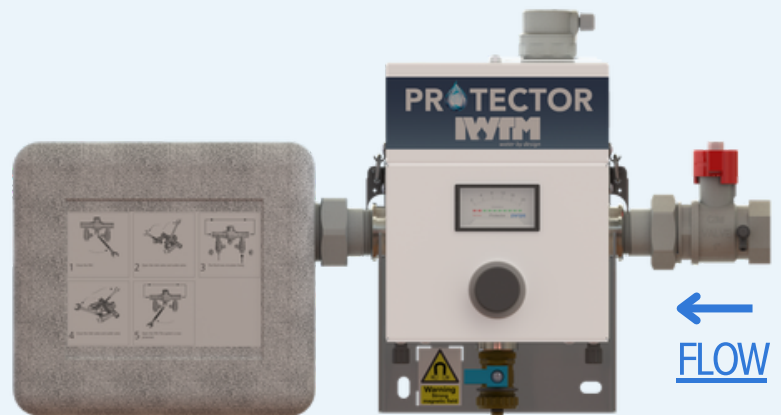

	Dry Weight (Kg)	Full Weight (Kg)	Shipping Weight (Kg)
P0.5F	7.0	7.9	9.5

DATA & MEASUREMENTS

PRESSURE DROP

Model	Pstatic (bar)	Flow (l/min)	Pressure Drop (bar)
P0.5F	1	30	0.21
P0.5F	3	30	0.16
P0.5F	5	30	0.12

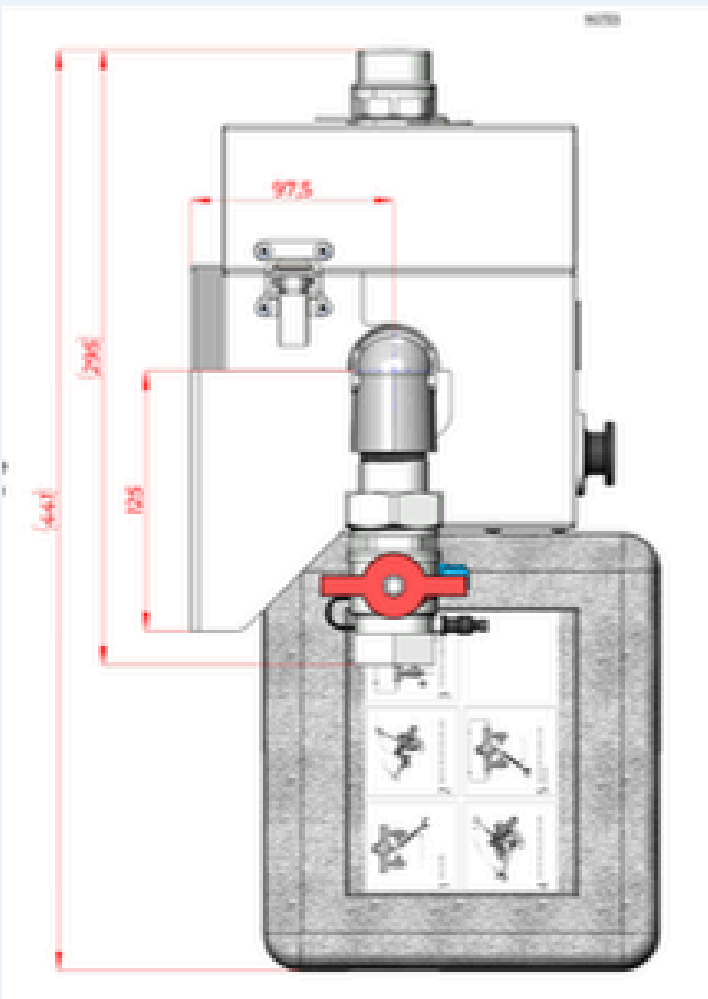
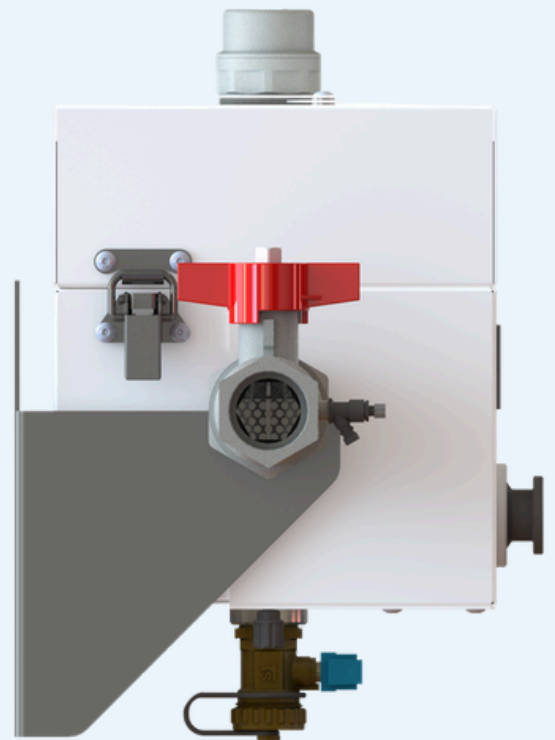

DATA & MEASUREMENTS

PROTECTOR P0.5F

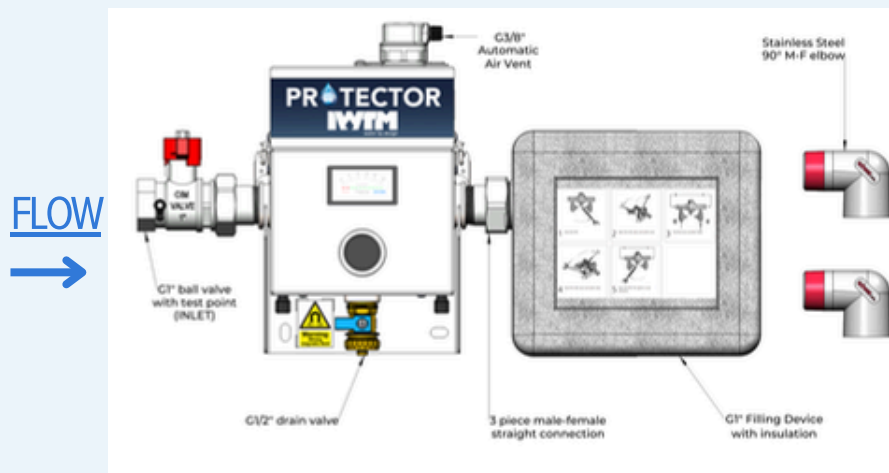
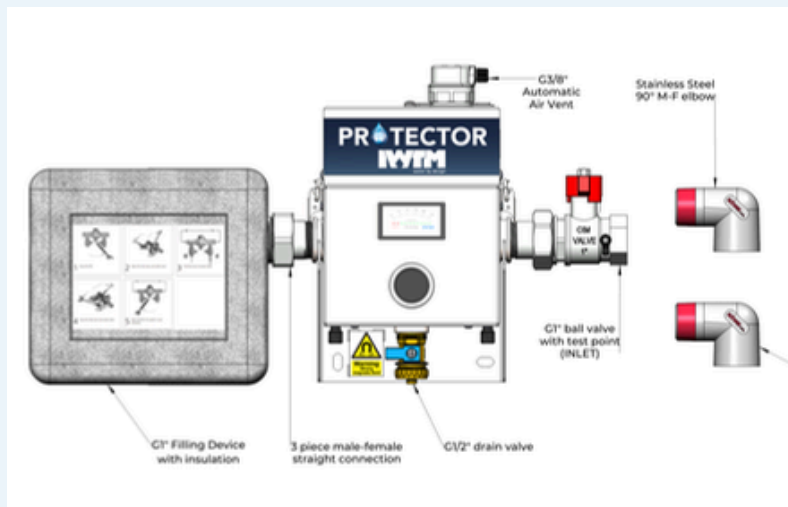
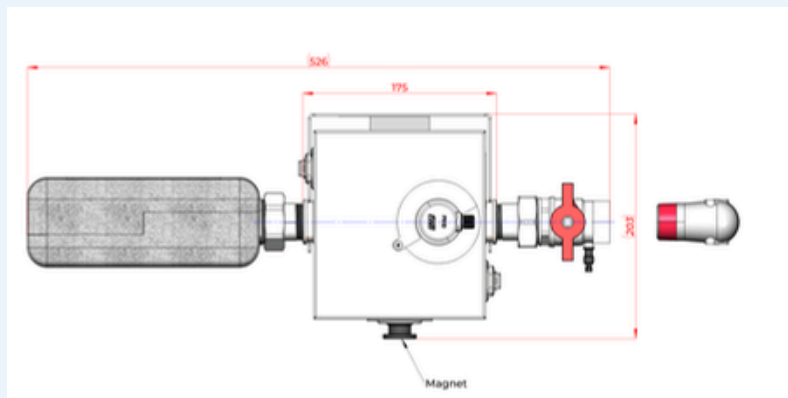

MAINTENANCE

ANALOGUE GALVANOMETER

The analogue galvanometer shows the galvanic current in milliamps between the anodes and the cathode (the tank body), with the system water being the medium.

The analogue galvanometer is always in a continuous reading position.

Pure water is non conducting, therefore the more impurities and oxygen in the water the more current will flow between the anode and the cathode.

When the water quality improves, the current diminishes and may measure even as low as 0.2 to 0.3 milliamps when the system water is fully passive.

The Protector system is self-regulating, the anode automatically works harder with corrosive water than with water that is no longer reactive.



The needle swing lies between 10% and 100%.

This is the normal operating region. The lower the reading, the less the anode needs to work, and the less impurities are in the system water.

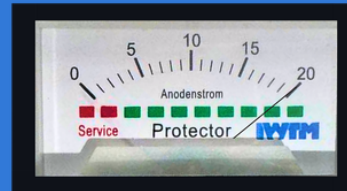

The needle always reads 100%.

The anode is working hard.

If the needle remains in this position for longer than one heating season, the Protector may be undersized for the system.

Action: check the system volume

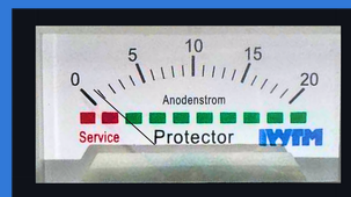

The needle lies continuously close to the red region.

The anode no longer needs to work because the chemical reactions in the water have finished, or the anode can no longer work because it is coated in a barrier layer...

MAINTENANCE

ANALOGUE GALVANOMETER

Action: remove the sludge from the Protector and fill with fresh water.

Keep the isolation valves closed, to hold the more corrosive fresh water inside the Protector.

If the operating meter shows a higher reading ,everything is operating correctly, and the Protector can be put back into operation. Otherwise, you need to open the lid to inspect the appliance.



The needle drops into the red region within a few weeks.

The anode is spent or coated in a barrier layer or the Protector is isolated from the system and no water is circulating through it.

Action: check circulation or open the appliance and clean or replace the anodes.

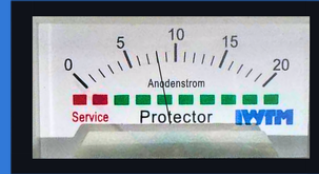

The meter continues to show a constant reading over a long period.

The operating meter might be faulty.

Action: Disconnect one wire from the anode holder and the needle should drop to the left.

If there is no change in the needle position, the meter is faulty.

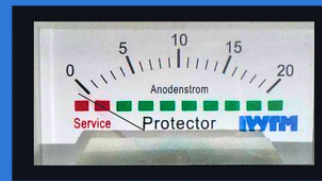

After servicing, if the indicator position is hard left in the red.

If the anode wires are connected wrong, it will create a short circuit and the swing meter will sit in the red zone – to correct this change the two connection wires around on the anode and the earth.

While the Protector is increasing the pH and scavenging oxygen the water gets less aggressive and the current will decrease and stabilise. (normally from 4-15 mA). If some chlorides or sulphates should interfere, resulting in higher conductivity or increased oxygen (feed water), the ampere & output will increase again.

MAINTENANCE

MAGNESIUM ANODE

The filter anode is encapsulated in a basket of stainless steel wire mesh and does not normally need any cleaning.

If however, its coated in slime from chemical residue or any other debris, this can be removed with a suitable scraper to get back to the bare anode surface after firstly removing the stainless steel wire mesh to reach the anode. Check the anode for proper functioning with a milliamp meter.

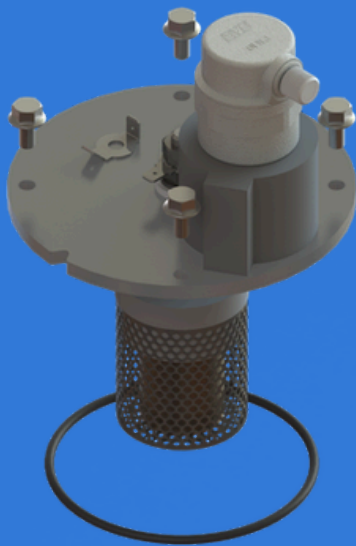

TOOLS:

- Isolating nut dry side 13 mm spanner
- Isolating bolt wet side 17 mm spanner
- Flange cover nuts 10 mm socket

SERVICE

Service on the Protector unit should be done once a year. However, this is also depending upon the quality of the system water.

If there has been an existing problem with sludge, sediments etc. before the Protector installation, we recommend a first service after 3 months of operation. It's also important to take a water sample out of the system, for analysis in a laboratory.

The anode isolation bolt going through the flange has two nylon washers one on each side of the flange. Once opened, they cannot be reused. These washers are not part of the anode replacement kit and come with the anode isolation bolt kit. So please do not undo the isolation bolt when replacing the anode.

Make sure not to rotate the bolt while changing the anode. Use a 17mm spanner to hold the isolation bolt securely whilst removing/fitting the anode. This will ensure the isolation screw does not turn. Once the anode has been replaced, use a test meter to check there is no continuity between the anode & the flange.

The two isolation washers have two functions

1. To create a watertight seal
2. To electrically isolate the anode from the tank.

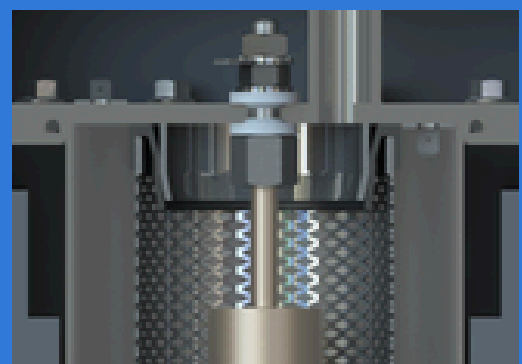

MAINTENANCE

Note: To avoid the potential risk of galling or cold welding which is a phenomenon that can happen when stainless steel threads lock together, in accordance with good engineering practise on the reassembly after any service work an anti seize paste should be applied to the bolt threads. Avoiding the use of power drivers can also reduce the risk of galling as the increased tightening speed creates heat that can accelerate this process.

SERVICE

- Close the inlet and outlet ball valves.
- Remove magnet and carefully set aside.
- **DO NOT handle if you have a pacemaker.**
- Remove the top case assembly
- Empty the tank through the drain valve.
- Disconnect the galvanometer cables.
- Unbolt the flange lid.
- Carefully lift up the lid, the anode is attached to the underside.
- Check the anode.
- Clean the anode, if the magnesium is below 10mm diameter, replace with a new one.
- Take out the strainer from the external filter and flush / clean.
- Clean the tank inside by washing through with clean water.
- Check all parts belonging to the Protector and clean them if required. (AAV and External Filter)

When replacing the anode hold the isolation screw going through the flange and unscrew the anode. After mounting a new anode, reassemble in reverse order make sure that all bolts are correctly torqued and that the electrical wiring is properly reinstalled. If there's no indication on the meter, the Protector is not working, so please check the wiring is correct.

TORQUE settings:

Insulation bolt 25Nm

Flange 14 Nm

When done, put everything back in place and fill up the Protector on the inlet.

When the air vent stops letting out air, the tank is refilled and you can open the outlet and start the circulation again.

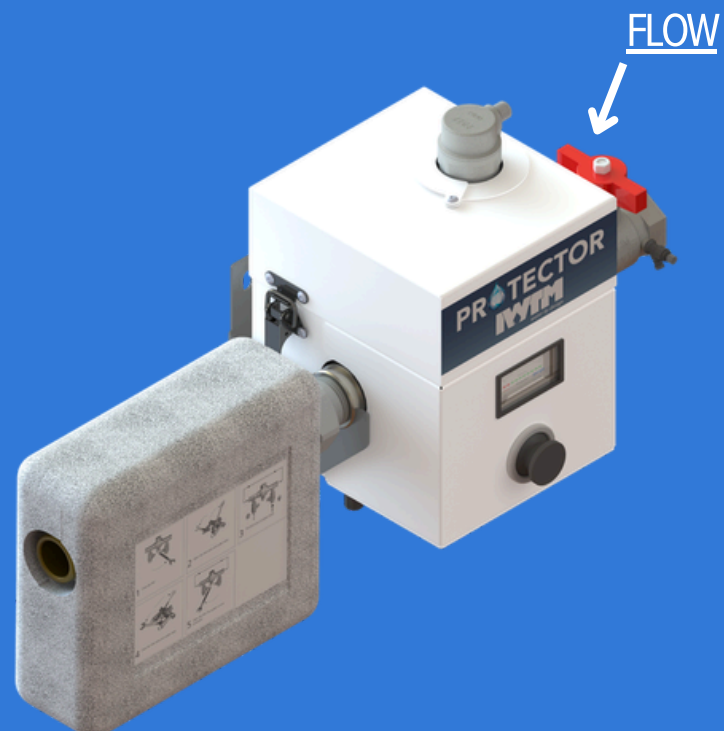

FILTER BY-PASS INSTRUCTION

FILTER BY-PASS ASSEMBLY

The filter by pass serves several functions, it is used as a service isolation valve, it is a filter ball valve with a magnet, it can be used for filling the system and for resin rinsing the system with a ProFill Prime mobile device.

CLEANING THE FILTER AND MAGNET

- The filter and magnet are cleaned by firstly closing off the filter ball valve – see section 1 on the drawing
- The top nut is then undone to lift away the filter and magnet – clean both items before replacing them and re-assemble in reverse order.
- Open the valve to re-instate the flow

FOR USE TO RESIN RINSE THE SYSTEM

- Connect the hoses from the ProFill Prime to the 3/4” valves. NOTE the valve closest to the Protector will be connected to the inlet connection on the Prime.
- Close off the filter ball valve as section 1
- Now you can open the ¾” valves as per section 3 and 4 – system water will now be diverted through the Prime mobile resin device.
- Once the rinsing is complete close off the ¾” valves and open the filter ball valve as per section 5

Please note: The valve closest to the Protector connects to the inlet on the Prime.

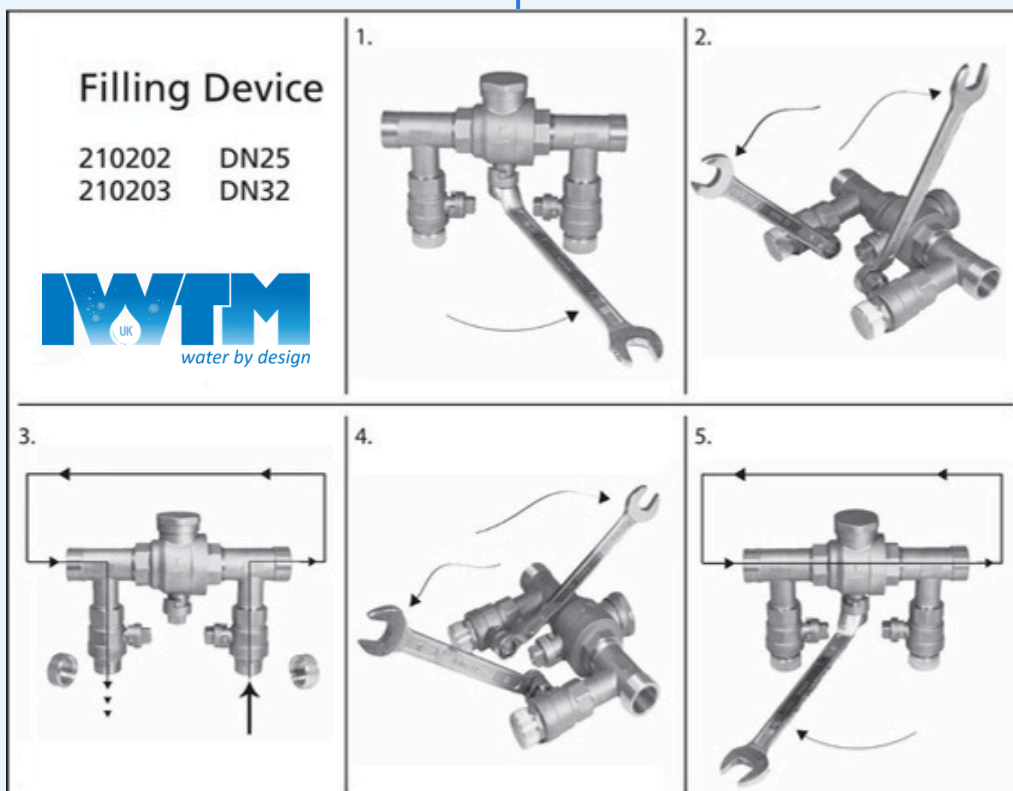

ACCESSORIES

Protector - Spare Parts	
Part No.	Description
F_00015	AIR VENT
F_00004	ANODE
F_00030	FLANGE O RING
F_00029	ANODE ISOLATION BOLT
VKP1001	GALVANOMETER
F_00001	FILTER BY PASS

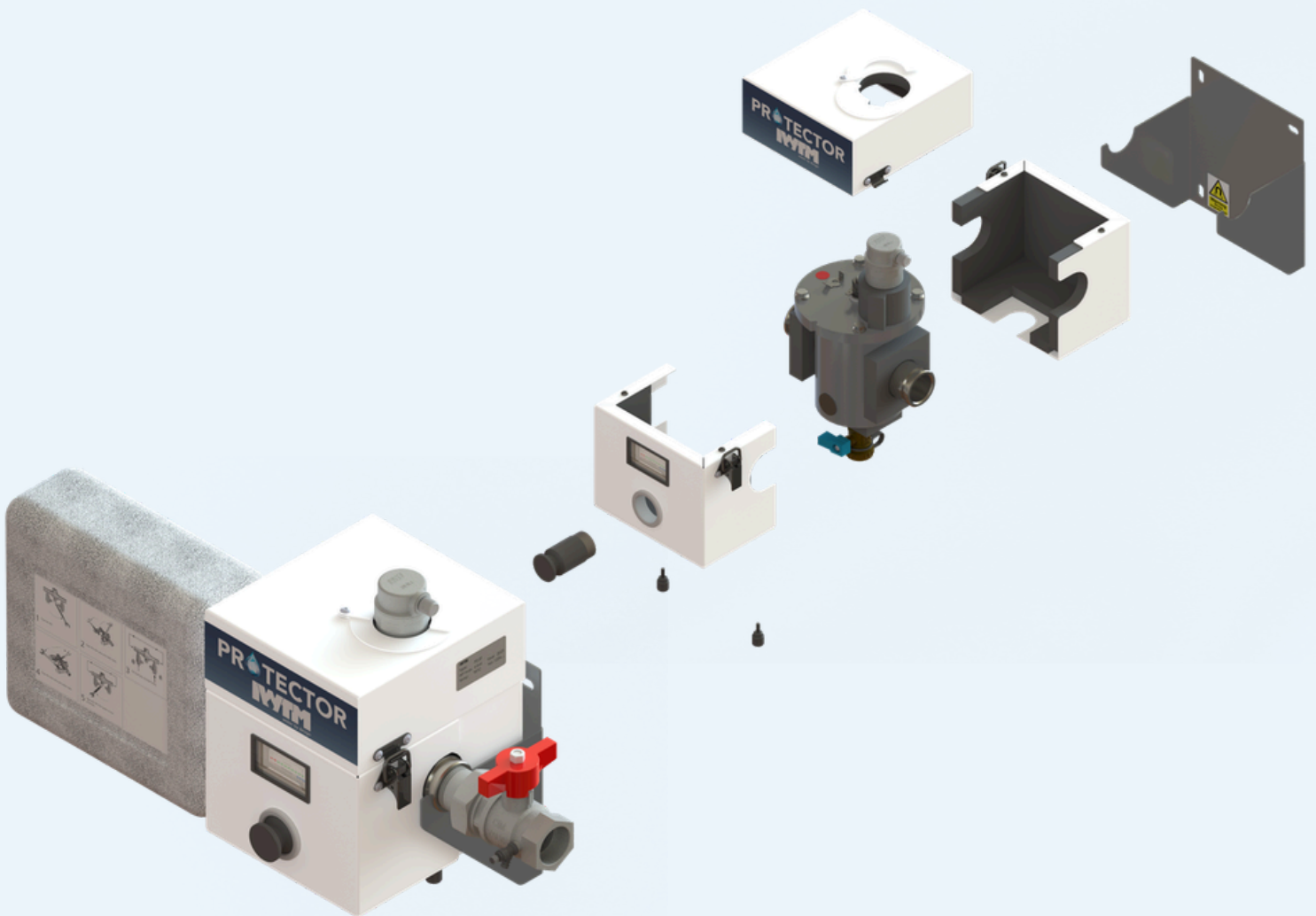

VALVE KIT

The UK Protector P0.5F is supplied with the following valve kit which is packed inside the main Protector box.

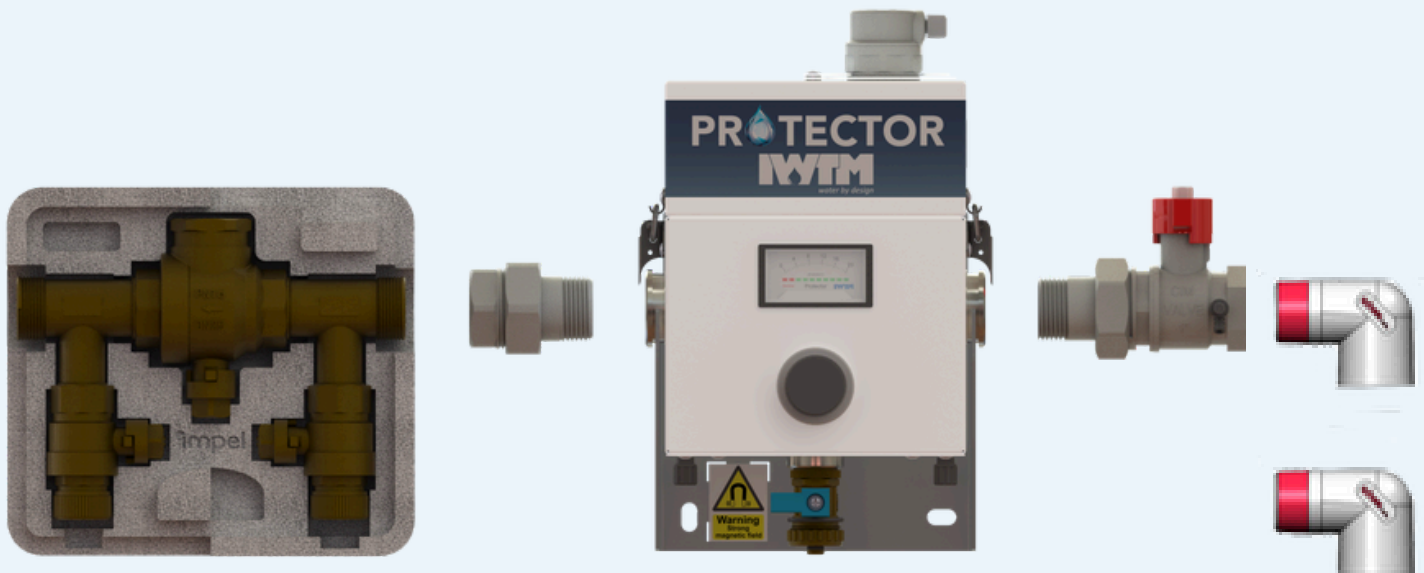

WARRANTY CONNDITIONS

The stainless steel tank assembly for IWTM Protector® units, including the Protector and ProFill, and the marine units, models T50/T100/T260/T500/T800 and T1000, is guaranteed for a period of 25 years against rusting through. This warranty is subject to the following conditions:

Protector/Industrial unit warranties will only be validated if the system is installed, in line with manufacturers recommendations, with an appropriate ProFill demineralising device ensuring that all manual or automatic make up and refill water is demineralised in accordance with VDI2035 and TM20

Periodic maintenance must be undertaken at least every 12 months in accordance with our manuals, proven to have been carried out by a specialist service company with clear, documented evidence.

This 25-year warranty only extends to the main tank and not to any supplied accessories, meters, AAV's, anodes, filters, etc. The warranty provides for a replacement unit only and not for labour or any other costs associated with the replacement of the equipment.

PLEASE SEE OUR FULL TERMS AND CONDITIONS ON YOUR
QUOTATION FOR FURTHER DETAILS



Founded in 1992, IWTM have been working with chemical free water treatment using electrochemistry for over 30 years and have offices in Norway, UK, Finland, Sweden, Canada, USA and a worldwide presence in the Marine sector.

We have developed models specifically suited to the higher demands of the marine industry operating at higher pressures and higher temperatures.

The marine products are provided worldwide on the world's largest cruise ships working with the leading operators in this sector.

Having secured DNV approval in 2003, we are still the only chemical free water treatment manufacturer to have this certification and approval. DNV is a globally leading quality assurance and risk management company operating in more than 100 countries.

The IWTM Protector® is our most recently developed product. The Protector range is now available to our land-based customers.

March 2026

In line with continued product development we reserve the right to make any changes to this document without any given notice.

PROTECTOR



SUTTON BUSINESS CENTRE
RESTMOR WAY
WALLINGTON SM6 7AH

WWW.IWTM-UK.COM
T: +44 208 255 2903
E: INFO@IWTM-UK.COM