

# PROFILL MANUAL

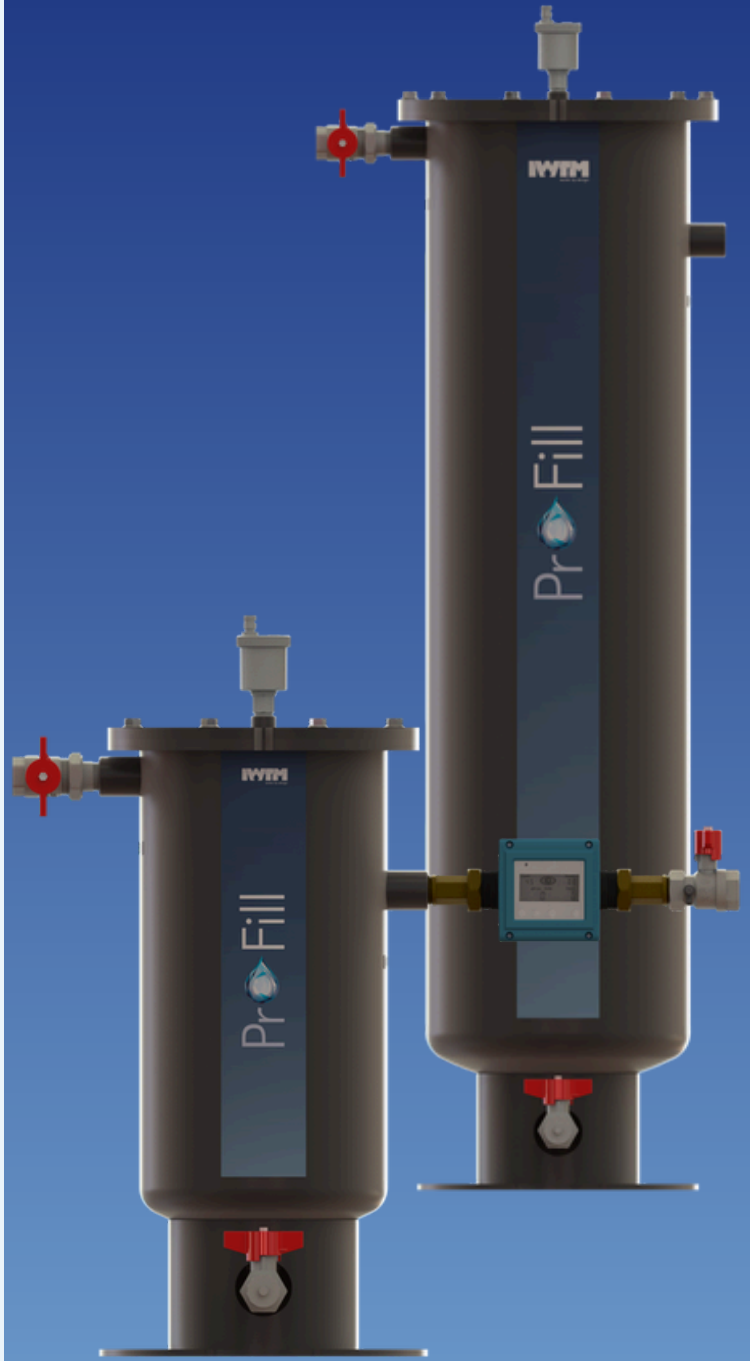

WWW.IWTM-UK.COM  
T: +44 208 255 2903  
E: INFO@IWTM-UK.COM

# TABLE OF CONTENTS

- 03** DESCRIPTION & FEATURES
- 04** INSTALLATION
- 05** SIZING
- 07** MEASUREMENTS
- 12** OPERATING THE METER
- 13** OPTIONAL CONDUCTIVITY METER
- 14** INITIAL FILLING AND REPLACING RESIN
- 15** ACCESSORIES
- 16** VALVE KIT
- 17** WARRANTY CONDITIONS
- 18** SERVICE JOURNAL



# DESCRIPTION & FEATURES

## WHAT IS PROFILL?

The ProFill is a range of simple, easy to use refilling and top up units for demineralised water for heating and cooling systems. Installed in line with the systems filling device, they ensure that when used with our controlled pH resin that the filling water is supplied in accordance with the VDI 2035 standard.

The range has 5 different sizes, to accommodate your system requirements. 2L, 4L, 12.5L, 25L and 50L.

The ProFill filters lime and aggressive substances such as sulphates, nitrates and chlorides out of the fill water. The appliance uses a mixed bed ion exchanger to provide demineralised water for any system size. This method does not emit any chemical additives into the water. The appliance operates without an external power connection.

The resin beads have two types of ion exchange with the untreated water. As the untreated water passes through the ProFill, positively charged ions from the water will swap with positive hydrogen ions on the resin (cation exchange).

Similarly, negative ions in the untreated water will swap with negative hydroxyl ions on the resin beads (anion exchange)

## 03

The ions will be exchanged until none is left in the water other than hydrogen and hydroxyl, making H<sub>2</sub>O, demineralised water.

VDI 2035, SWKI Directive BT102-01 and other European standards state that water for filling heating systems should generally be demineralised for low salt operation. Practical experience has shown that even at a low hardness level, modern appliances such as wall mounted gas boilers, heat pumps and solar thermal systems can suffer damage from limescale deposits.

Compared to water that has been softened, demineralised water no longer contains any salts. Its electrical conductivity is extremely low, allowing it to act as a corrosion inhibitor.

## IN LINE WITH APPLICABLE STANDARDS & GUIDANCE

It has long been clear to experts in the field that fully demineralised water is ideal for filling heating systems and that this will extend the service life of all components. Today, this technology is so user friendly and affordable that it recommends itself for practical application.

The process of full demineralisation is therefore ideal for ensuring that the water quality requirements of the following directives and standards are met:

- VDI Guideline 2035
- SWKI BT 102-01
- ÖNORM 5195-1
- DIN50930
- CIBSE Heat Network Code of Practice + Heat Network Design Guide

# INSTALLATION

ProFill can operate at up to 10 bar and is therefore suitable for making a permanent connection between the mains supply and the heating system.

Depending on national or local regulations, a direct connection may be subject to technical conditions, which must be observed.



**Please make sure the meter is mounted in the direction of the flow of water away from the ProFill.**

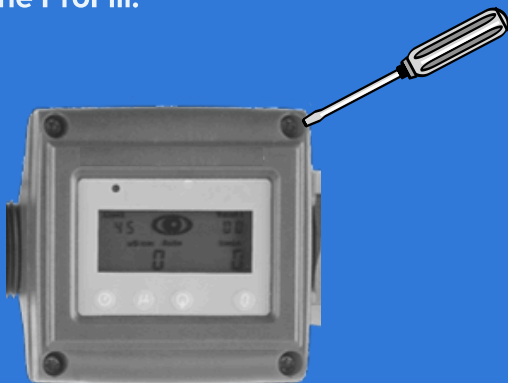

**The orientation of the meter head can be rotated to suit the mounting position so that it can always be easily read. Remove the 4 screws, gently rotate the head on the connection wires and screw the head back on in the desired position.**

## TYPICAL PROFILL INSTALLATION BEFORE PU, PU-DEGASSER OR SPILL UNIT

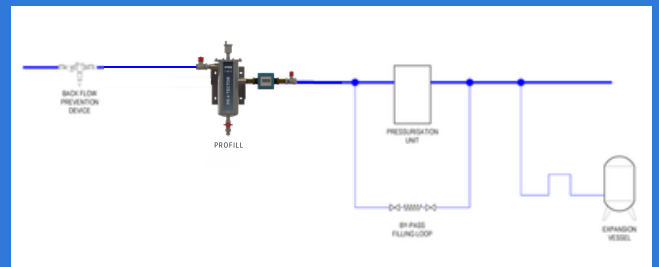

## SAFETY INSTRUCTIONS:

The regulations of the water utility must be observed when connecting directly to the mains supply (e.g. system separator to DIN EN 1717).

After use, valves to the heating system and mains supply must be closed.

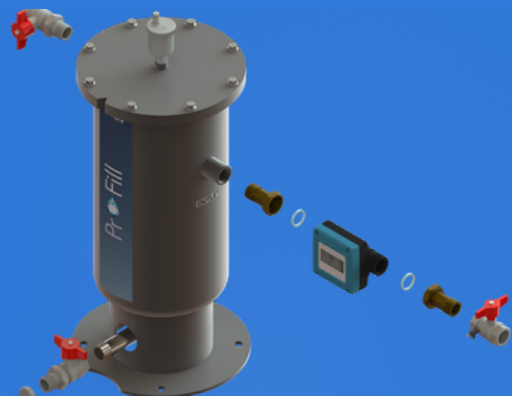

## INSTALLING CONNECTIONS

- 1 pc 3/4" M x F Union Isolation Valve - Inlet Valve with NRV
- 2 pc 3/4" M x 1" F Union
- 3/4" F x F Isolation Valve - with test point
- 1/2" F x F Isolation Valve - with cap for drain (for 2L & 4L)
- 3/4" F x F Isolation Valve - with cap for drain (for 12.5L, 25L & 50L)
- Conductivity Meter

# SIZING



ProFill Unit	Max Pressure	Max Temp	Delivery Capacity	Total Height	Overall Width	Empty Weight	Shipping Weight
ProFill 2l	10 bar	95°C	5 l/min	525 mm	277 mm	6.55 kg	8 kg
ProFill 4l	10 bar	95°C	5 l/min	740 mm	277 mm	8.08 kg	10 kg
ProFill 12.5l	10 bar	95°C	20 l/min	651 mm	370 mm	20 kg	24 kg
ProFill 25l	10 bar	95°C	20 l/min	761 mm	422 mm	32 kg	37 kg
ProFill 50l	10 bar	95°C	20 l/min	1221 mm	422 mm	46 kg	50 kg

# SIZING

## SIZING GUIDE REQUIREMENTS

A ProFill should ideally be sized to accommodate 1% of the system water volume being replenished per annum for a good heating or cooling installation.

The size will depend on the incoming water hardness where the ProFill is being installed. The annual fill rate of the system can be more than 1% in some circumstances and this will affect the selection as a larger unit may be required to accommodate system issues. You can find your water company and then your water hardness guide from your local water provider.

<https://www.water.org.uk/advice-for-customers/find-your-supplier/>

	2 °dH	7 °dH	15 °dH
<b>ProFill 2</b>	1666	476	333
<b>ProFill 4</b>	3,333	952	666
<b>ProFill 12</b>	10,000	2,857	1,333
<b>ProFill 25</b>	20,000	5,714	2,666
<b>ProFill 50</b>	40,000	11,428	5,332

Table showing what the approximate filling capacity in litres is with different water hardness in degrees German °dH , for the ProFill range.

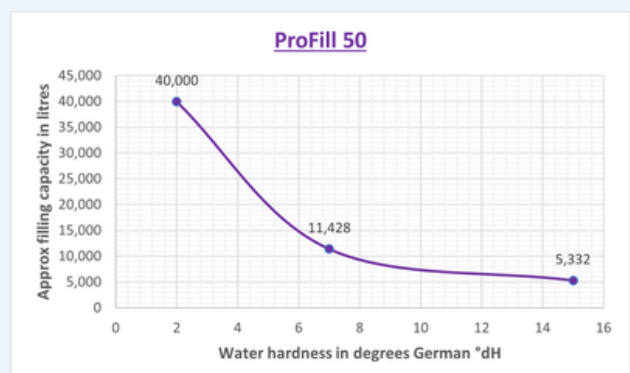
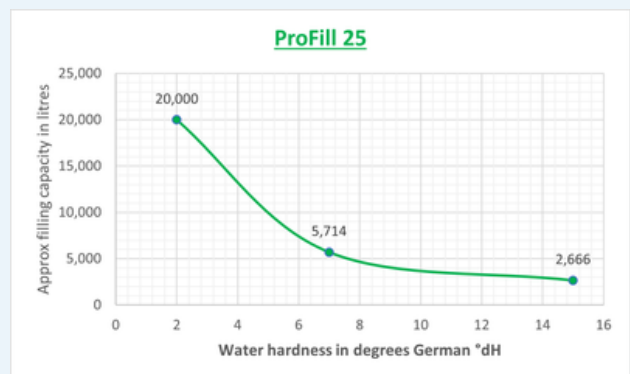
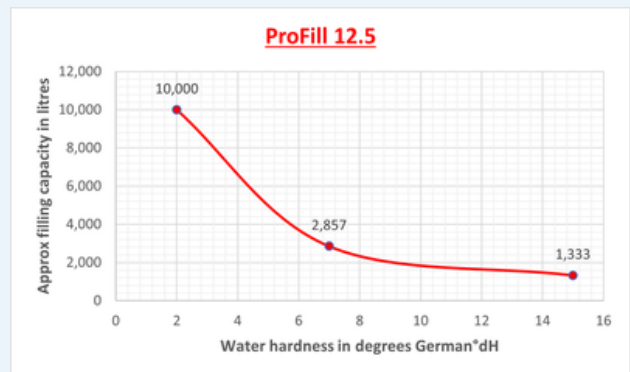
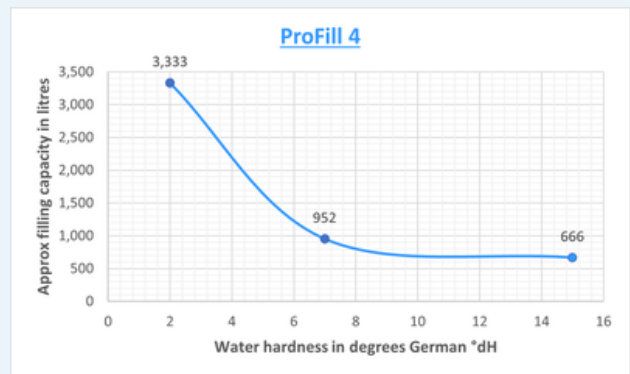
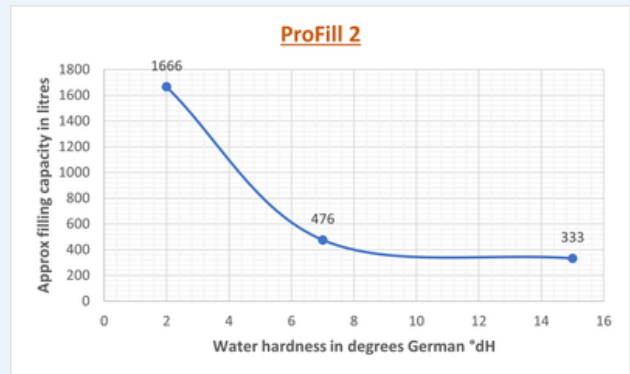

# MEASUREMENTS

## PROFILL 2L:

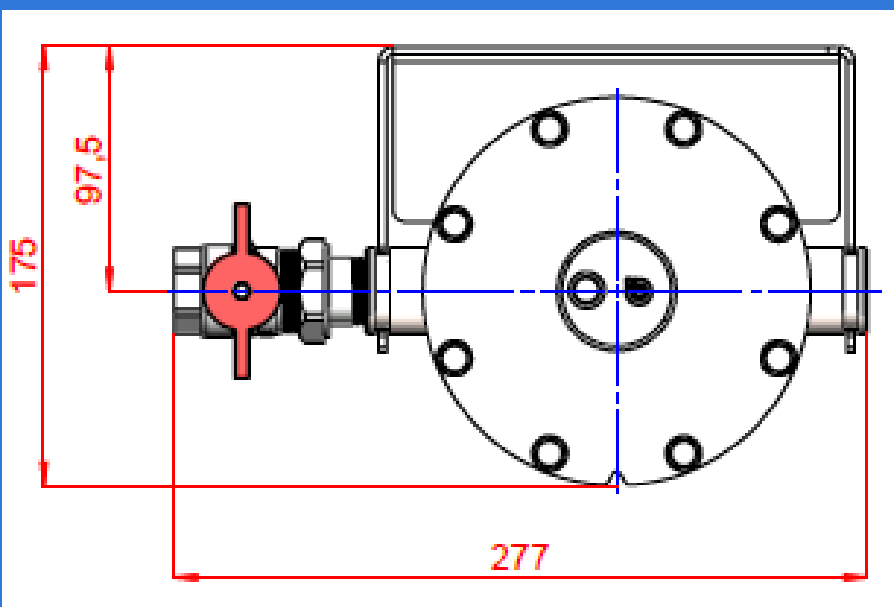
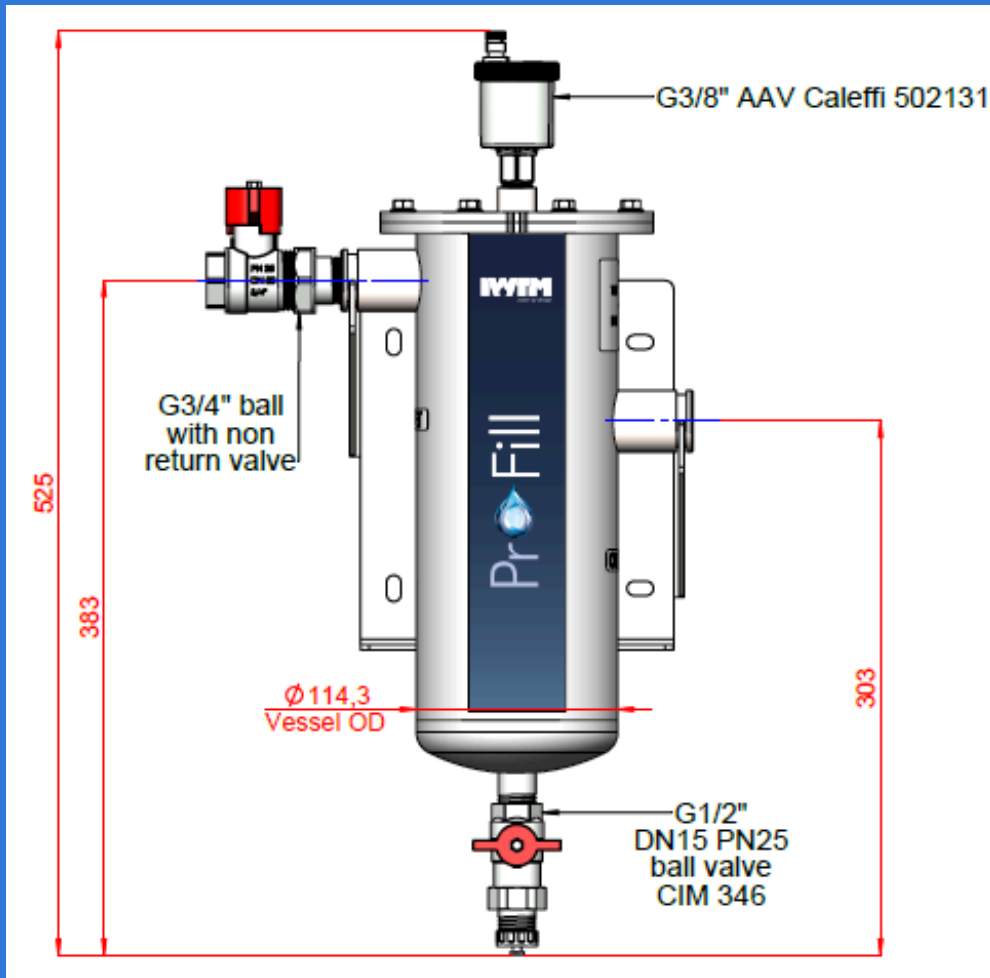

# MEASUREMENTS

## PROFILL 4L:

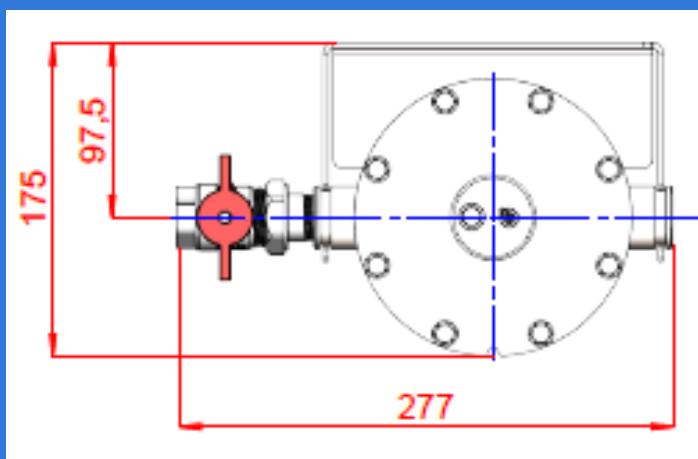
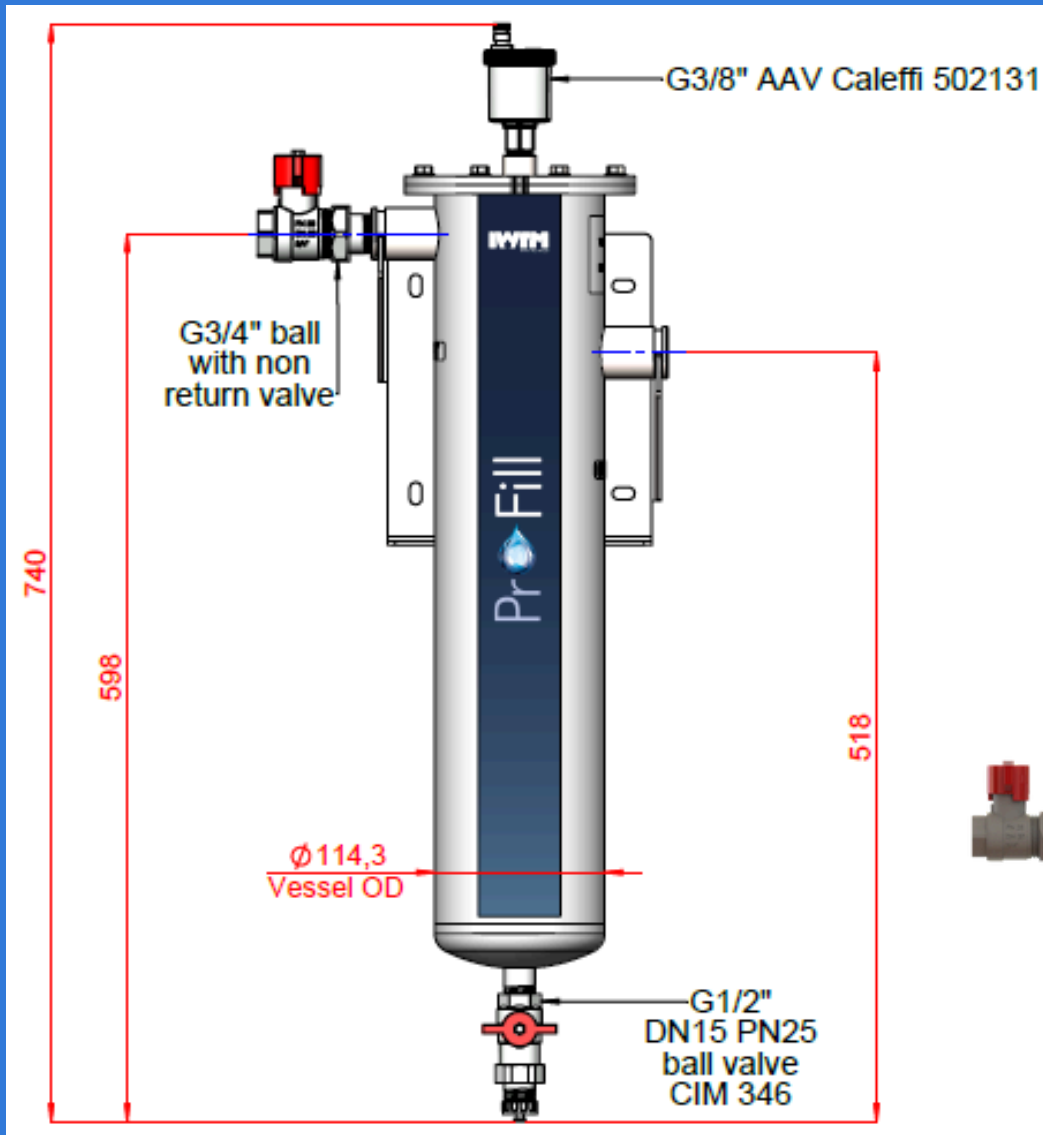

# MEASUREMENTS

## PROFILL 12.5L:

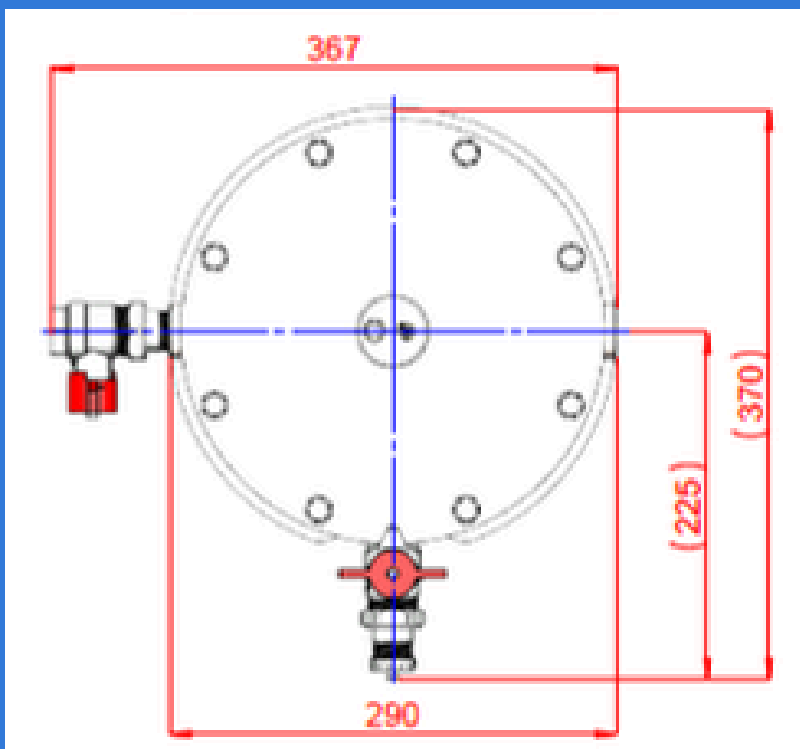
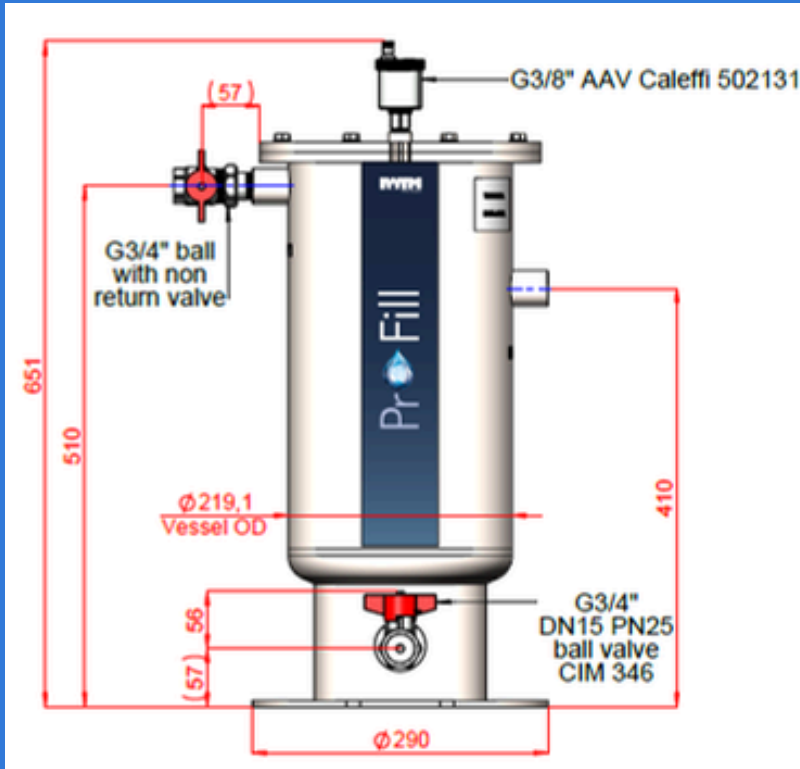

# MEASUREMENTS

## PROFILL 25L:

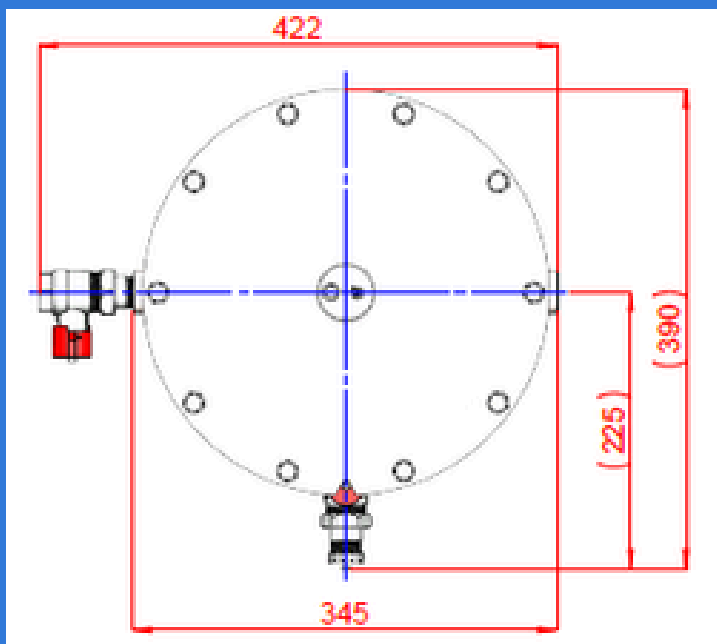
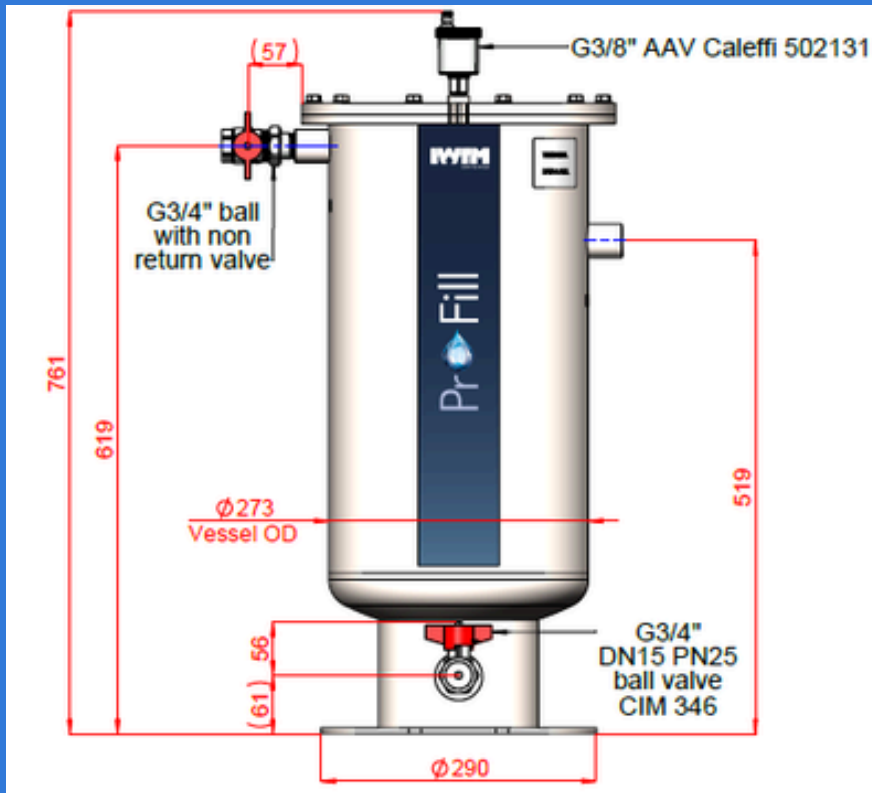

# MEASUREMENTS

## PROFILL 50L:

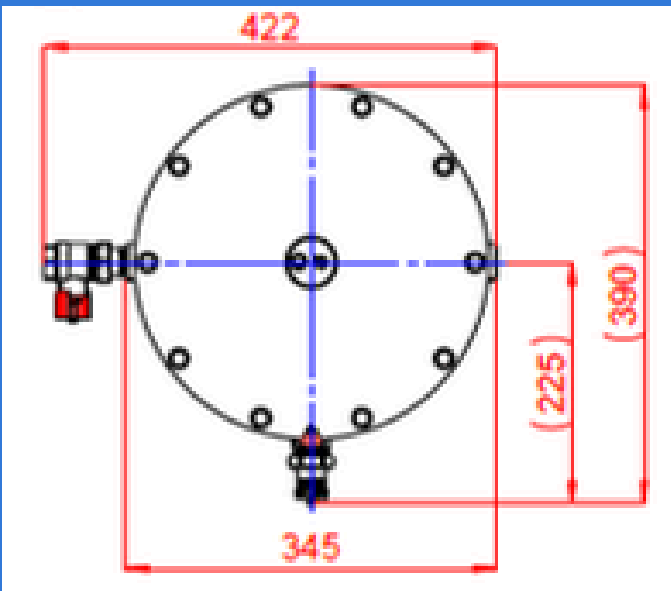
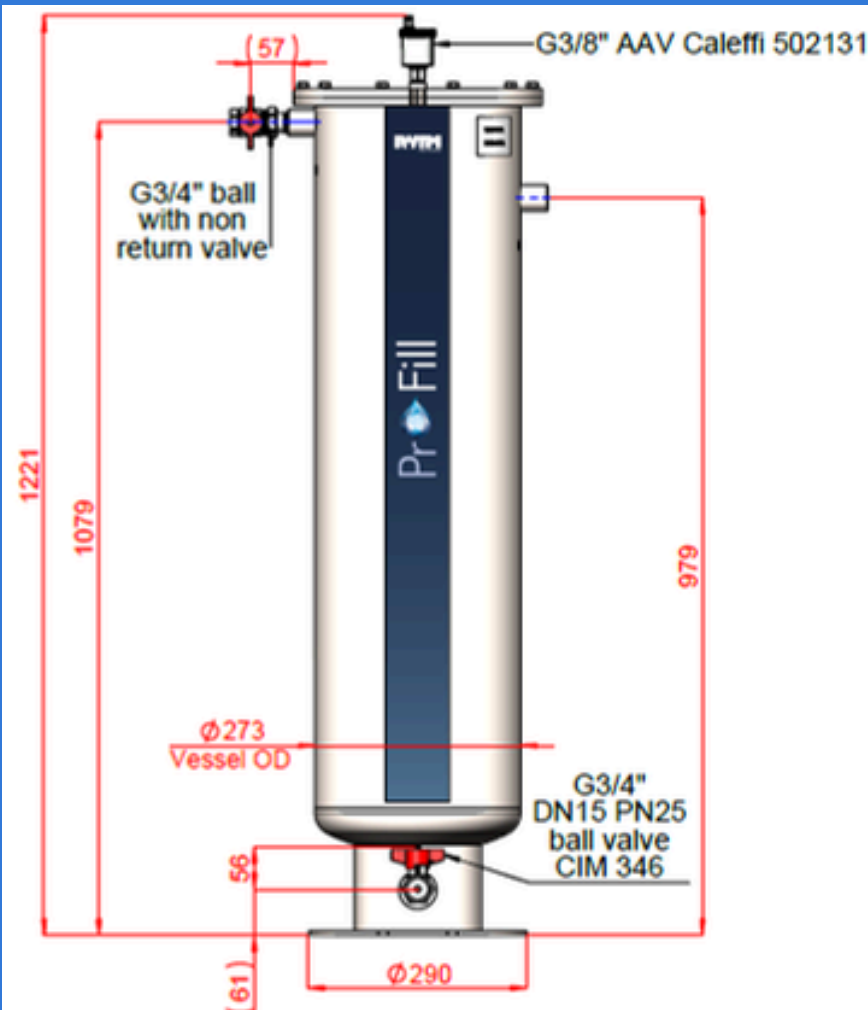

# OPERATING THE COMBINED METER

The combined meter is battery-operated. It measures the flow rate in l/min, the total volume in litres and the concentration of dissolved minerals (electrical conductivity), either in micro siemens or ppm. In addition, a limit can be set for the maximum concentration of minerals tolerated in the demineralised water (ProFill outlet). The limit and flow rate total can both be reset.

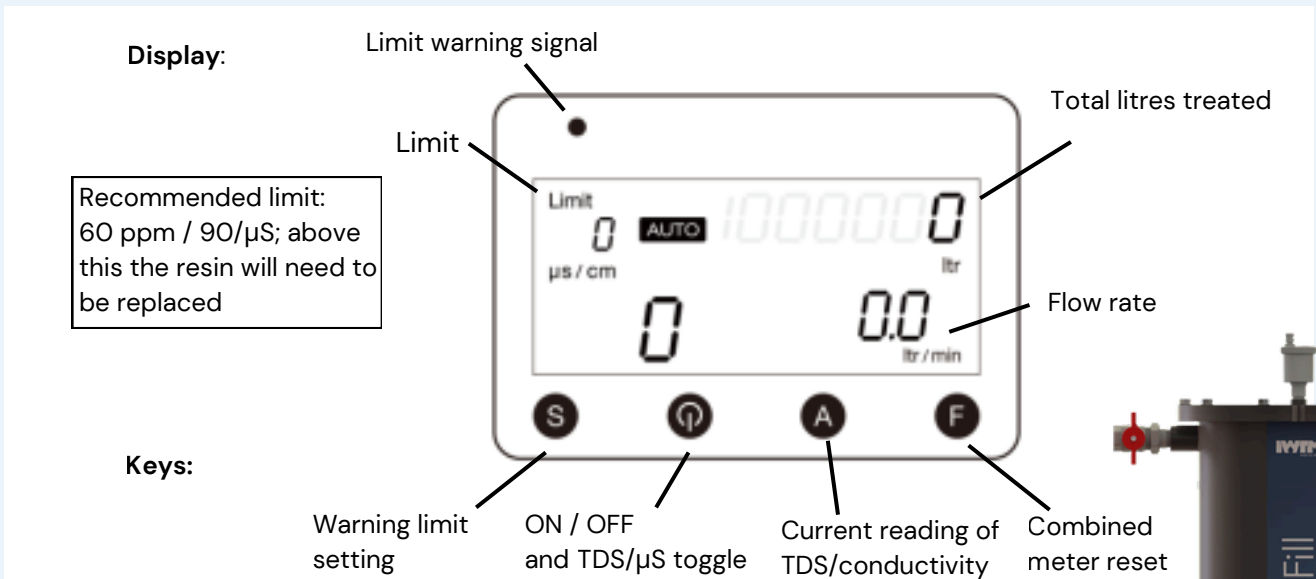

- 1 Installing battery - take out the screws of the front case, and put three AA alkaline batteries into the battery holder. The front case can be rotated from 90, 180 to 270 degree for better reading.
- 2 Setting litre or gallon mode - The default setting of the meter is litre. You can switch the mode from litre to gallon by the keep pressing the button "F" when install battery. When a beep sound heard, the setting is switched. The screen shows "gal / min".
- 3 To turn on and turn off, keep pressing the "P" button for three seconds.
- 4 Setting TDS or conductivity - The default setting of the meter is a conductivity mode. The screen shows "uS/cm". You can switch the mode between the conductivity and TDS (Total Dissolved Solid) by the pressing the button "P".
- 5 Measuring flow - The meter shows real time flow rate and accumulated volume. The maximum accumulated volume is 1999999 litres (gallons).
- 6 Manual measuring TDS / Conductivity - Press the button "A" can measure the TDS or conductivity and keep showing the value on the screen. The maximum TDS and conductivity can be measured is 1999 ppm and 1999 uS/cm.
- 7 Automatic TDS/Conductivity monitoring - Press the button "S" can set the TDS or conductivity value to monitor. The increment is 10 ppm for TDS and 15 uS/cm for conductivity. Keep pressing the button "S" can reset the setting to be zero.

- 8 Automatic / Manual mode - Press the button "A" can switch between the automatic and manual mode for the TDS/Conductivity measuring.
- 9 Release the alert - By pressing the button "A" to choose the mode to be manual mode will release the alert status.
- 10 Low battery power alert - When the battery power is low, the empty battery symbol on the screen blinks. Replacing the battery by new ones can release the alert. The last data will be memorized and restored when battery power is off.

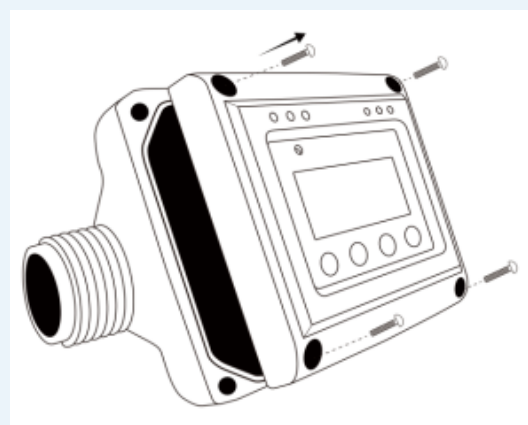

Once the setting is done, then go to set automatic monitoring function. Press the button "A" to do manual test first, then press the button "A" again, the meter get into automatic monitoring function. The screen shows "AUTO" in the middle. The meter measure the TDS / conductivity for every 10 litres. If the measured value is under the setting value, the green light blinks 30 seconds. If the measured value is over the setting value, the red light keeps blinking, and the alarm generated.

# OPTIONAL CONDUCTIVITY METER FOR USE WITH BMS SYSTEMS

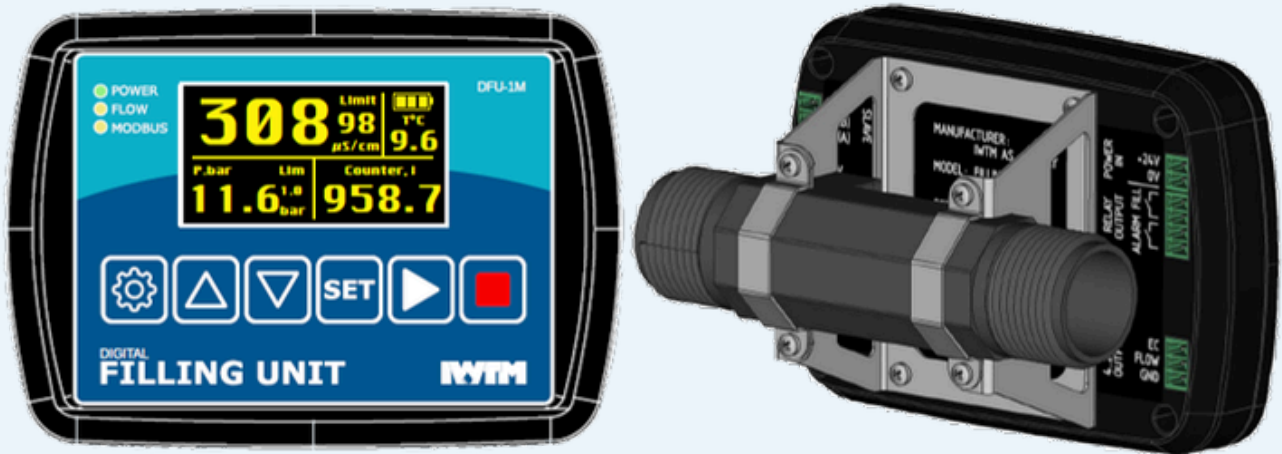

The Digital Filling Unit is a device for measuring water conductivity, temperature, flow and total volume passed.

The DFU is able to control a filling valve when fitted by applying a setting where the valve will be closed to stop the flow of water and send alerts when the resin is expiring and the conductivity is too high.

The unit has 4 no. 20mA outputs and Modbus/RTU allowing connection to a building management system (BMS).

Please refer to the Digital Filling Unit manual for further information.

# INITIAL FILLING & REPLACING THE RESIN

**Note:** To avoid the potential risk of galling or cold welding which is a phenomenon that can happen when stainless steel threads lock together, in accordance with good engineering practise on the reassembly after any service work an anti seize paste should be applied to the bolt threads. Avoiding the use of power drivers can also reduce the risk of galling as the increased tightening speed creates heat that can accelerate this process.

## INITIAL FILLING

1. Undo bolts and remove the lid and seal.
2. Pour in the new resin. Replace the seal ensuring there is no resin on the seal.
3. Replace the lid and tighten the bolts.
4. Reset the meter to 0.
5. Open the inlet valve and automatic air vent. When all air is dispensed open the outlet valve.
6. Check the lid is sealed and water tight.

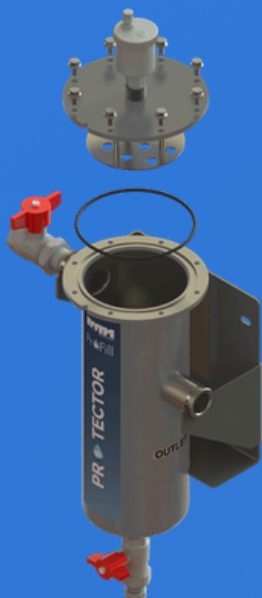

## REPLACING THE RESIN

1. Close ball valve in the outlet, connect a hose at the drain valve and route into the supplied collection sack; flush out the resin at mains pressure. Close the inlet valve and drain water, and close drain valve.
2. Continue by following the steps from 'Initial Filling'

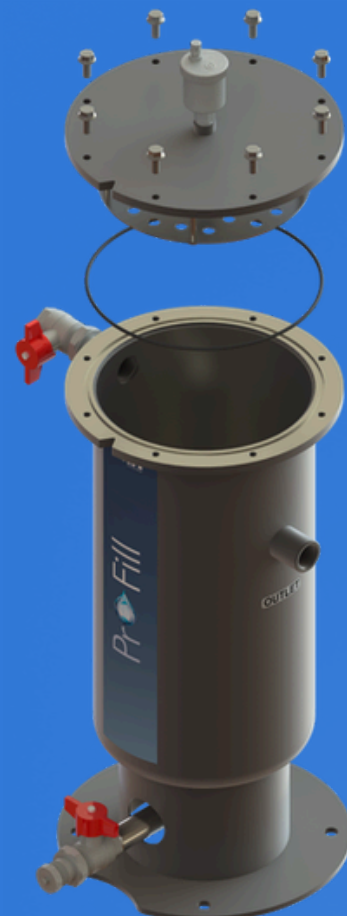

# ACCESSORIES

Part No.	Description
<b>ProFill - Complete Units</b>	
170102	PROFILL 2L 3/4" WITH VALVE KIT AND FLOW METER, AISI 304
170103	PROFILL 4L 3/4" WITH VALVE KIT AND FLOW METER
170104	PROFILL 12.5L WITH VALVE KIT AND FLOW METER 3/4", AISI 304
170105	PROFILL 25L WITH VALVE KIT AND FLOW METER 3/4", AISI 304
170106	PROFILL 50L WITH VALVE KIT AND FLOW METER 3/4" , AISI 304
<b>ProFill - Valve Kit</b>	
KIT ACCESORIL_PRL	PROFILL VALVE KIT 3/4"
<b>ProFill - Spare Parts</b>	
101540	FLOW METER 3/4"
502131	3/8" AAV CALLEFFI
PRL2-01-04	DIP Tube Filter Assembly
F_00029	FLANGE O RING 2L/4L
F_00150	FLANGE O RING 12.5
F_00162	FLANGE O RING 25/50
MPR_03221	FLANGE BOLTS 2L/4L
MPR_08842	FLANGE BOLTS 12.5/25/50
<b>ProFill - Ion Exchange Resin</b>	
101651	PRIME PH RESIN 12.5L
101650	PRIME PH RESIN 4L
201649	PRIME PH RESIN 2L

# VALVE KIT

The ProFill is supplied with the following valve kit which is packed inside the main ProFill box.

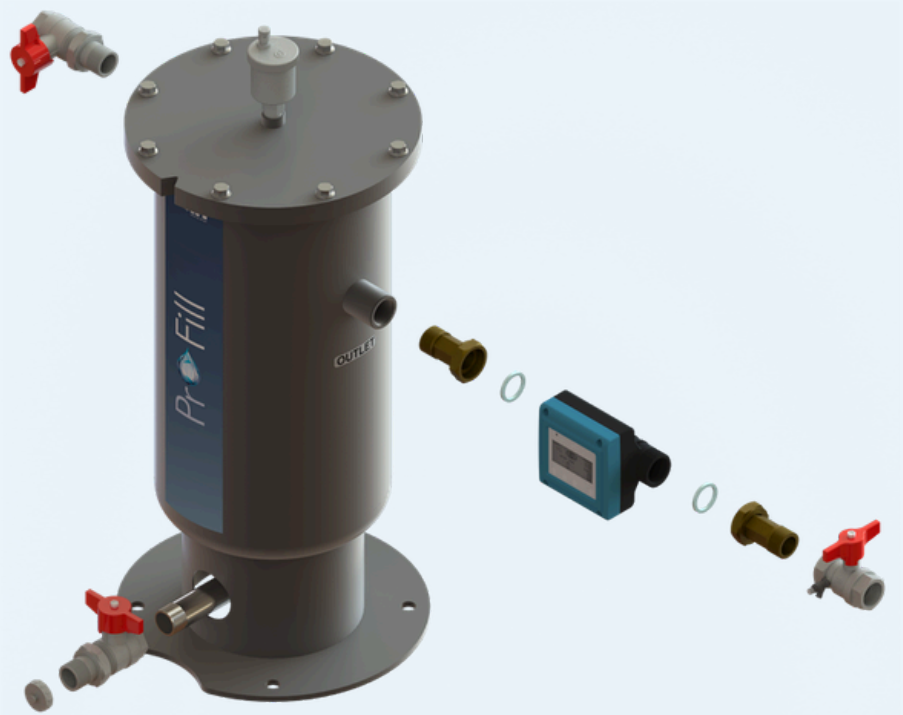

The valve kit must be installed as per the diagram. The inlet is on the left and only the inlet valve with an arrow should be installed on the inlet, as it has a one way non-return valve built in.



# WARRANTY CONNDITIONS

The stainless steel tank assembly for IWTM Protector™ units, including the Protector and ProFill, and the marine units, models T50/T100/T260/T500/T800 and T1000, is guaranteed for a period of 25 years against rusting through. This warranty is subject to the following conditions:

Protector/Industrial unit warranties will only be validated if the system is installed, in line with manufacturers recommendations, with an appropriate ProFill demineralising device ensuring that all manual or automatic make up and refill water is demineralised in accordance with VDI2035.

Periodic maintenance must be undertaken at least every 12 months in accordance with our manuals, proven to have been carried out by a specialist service company with clear, documented evidence.

This 25-year warranty only extends to the main tank and not to any supplied accessories, meters, AAV's, anodes, filters, etc. The warranty provides for a replacement unit only and not for labour or any other costs associated with the replacement of the equipment.

PLEASE SEE OUR FULL TERMS AND CONDITIONS ON YOUR  
QUOTATION FOR FURTHER DETAILS





# Environmental Culture Change

*be a part of it*

clean | protect | prevent



Founded in 1992, IWTM have been working with chemical free water treatment using electrochemistry for over 30 years and have offices in Norway, UK, Finland, Sweden, Canada, USA and a worldwide presence in the Marine sector.

We have developed models specifically suited to the higher demands of the marine industry operating at higher pressures and higher temperatures.

The marine products are provided worldwide on the world's largest cruise ships working with the leading operators in this sector.

Having secured DNV approval in 2003, we are still the only chemical free water treatment manufacturer to have this certification and approval. DNV is a globally leading quality assurance and risk management company operating in more than 100 countries.

The IWTM Protector™ is our most recently developed product. The Protector range is now available to our land-based customers.

Version 8: Jan 2026

*In line with continued product development we reserve the right to make any changes to this document without any given notice.*

# PROTECTOR



SUTTON BUSINESS CENTRE  
RESTMOR WAY  
WALLINGTON SM6 7AH

WWW.IWTM-UK.COM  
T: +44 208 255 2903  
E: INFO@IWTM-UK.COM