

# INDUSTRIAL / MARINE MANUAL

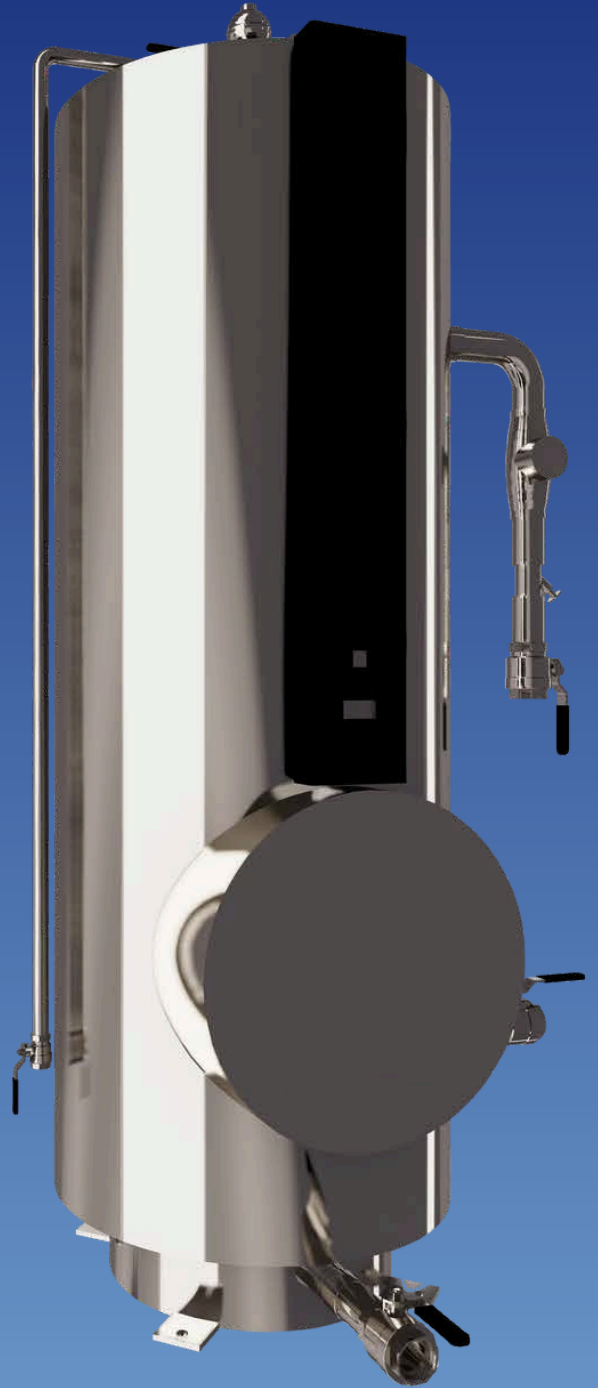

WWW.IWTM-UK.COM  
T: +44 208 255 2903  
E: INFO@IWTM-UK.COM

# TABLE OF CONTENTS

03	DESCRIPTION & FEATURES
05	INSTALLATION
11	DATA & MEASUREMENTS
17	MAINTENANCE
21	ACCESSORIES
22	PROJECT PICTURES
23	SERVICE JOURNAL

# DESCRIPTION & FEATURES

## WHAT ARE THE INDUSTRIAL / MARINE UNITS?

The industrial/marine units are reaction tanks equipped with pure sacrificial magnesium anodes that provide chemical-free water treatment. The units are installed through a bypass onto the water flow of any heating or cooling water circuit.

Through a cathodic/anodic reaction with the sacrificial anode, oxygen that enters the system is reduced to a safe level. This process results in the formation of magnesium hydroxide, causing the water's pH to increase to an optimal level.

Depending on the system's water composition, the electrical conductivity is lowered as the water's hardness diminishes. Therefore the production of alkaline water with low salt content and minimal oxygen concentration is produced.

The units work on the principle of cyclone filtration that effectively captures particles within the flow and deposits them at the base of the tank. The sludge can then be removed easily by draining the unit, until the water is completely clear / achieves VDI 2035 standards.

It is recommended, for optimum results, that system water which has been treated with chemicals or contains a large amount of corrosion sludge should be thoroughly rinsed with suitable IWTM Protector or Resin device before the marine/industrial unit is installed. Another option is to install the tank for 3 months and then carry out a controlled rinse.

Routine maintenance involves cleaning the anodes as needed and replacing them every three years on a new system ; old systems will require maintenance more often. Our units stands out as a market-leading product for corrosion protection, having proven its efficacy in heating and cooling systems for over 30 years. This technology is highly recommended for protecting new systems and revitalizing existing ones. Effective water treatment, ensuring a clean system, can yield energy reductions ranging from 2% to 7%. No unfriendly environmental waste is left.

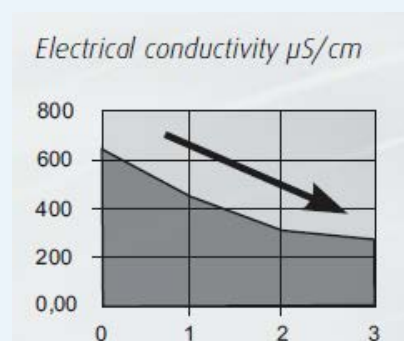
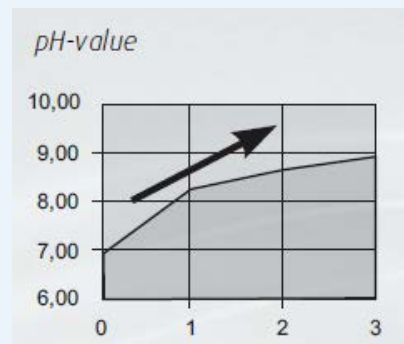
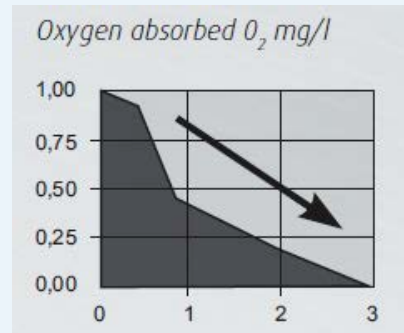

*Reduced oxygen + increased pH value  
+ reduced electrical conductivity  
= increased protection*

# DESCRIPTION & FEATURES

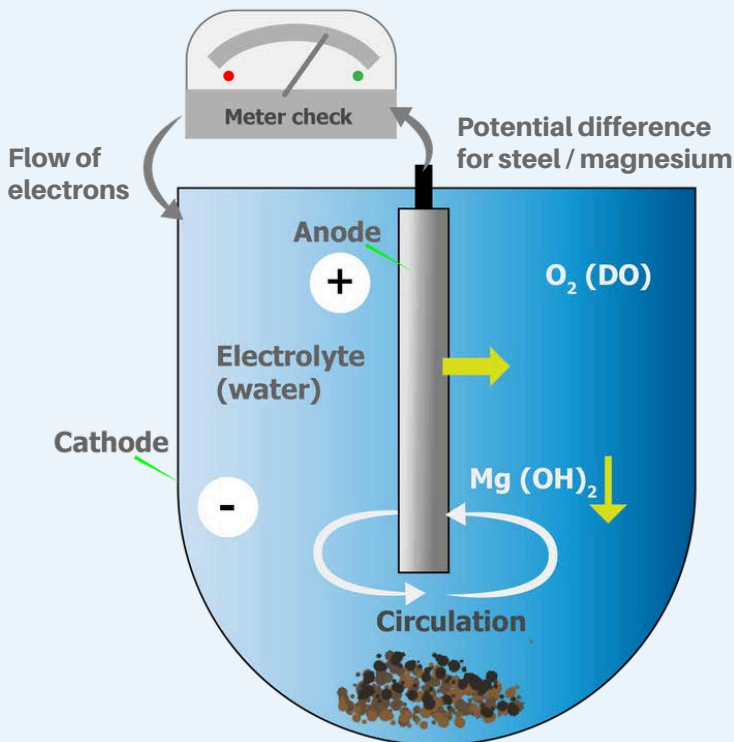

**Impurities filtered out by cyclone circulation**

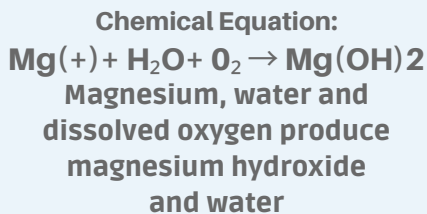

### 1) pH - Value

Corrosion is also due to acidic water. (low pH-value, water produced from sea water by evaporation, normally holds a pH at aprox.5.5) The industrial / marine unit automatically regulates the pH value to approx. 9 to 10 (this is caused by splitting of magnesium hydroxide from the anodes).

### 2) Electrical Conductivity

100% pure water is non-conducting. It is important that electrical conductivity is kept as low as possible in order to avoid galvanic corrosion as well as to reduce the stress on pumps, gaskets, heat exchangers etc. the efficiency of the unit is proportional to the conductivity, which means that the unit is regulating itself in accordance to the condition in the water. The more impure the water, the harder the unit will work itself.

### 3) Deposits

Major parts of the deposits are oxides of iron and other common metals. They are a result of corrosion due to an oxygen surplus, low pH or a galvanic current. The amount of dissolved metal is a measure for the ongoing corrosion process in your system. Through the industrial/marine unit the water will be neutralised and metallic surfaces stabilised. Corrosion is therefore stopped and the water stays clear, clean and without sediments. The deposit sludge is simply removed by draining the unit and cleaning other filters on the system.

# ATTENTION

All industrial units are delivered in crates and are fixed from their base plate holes with bolts to the end of the crate

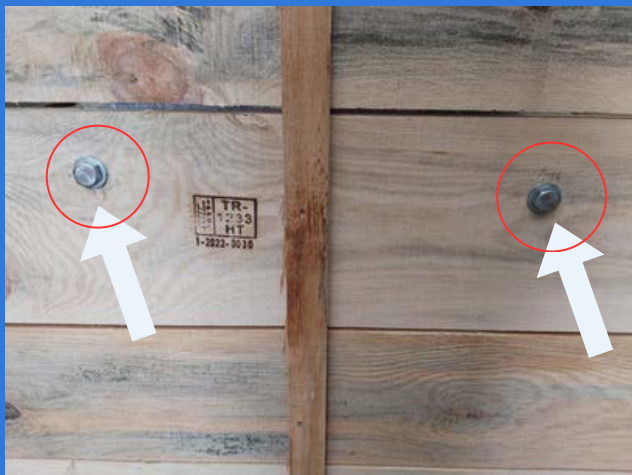

# INSTALLATION

## CLOSED LOOP HEATING AND COOLING SYSTEMS

The unit is to be mounted as shown below, in a by-pass position preferably over the main pumps; a line from the common discharge of the pumps is connected to the inlet of the unit (bottom).

Another option is to install our unit and create a side stream installation using its own pump.

The outlet from the unit (Top) is connected to the common inlet of the pumps.

The water flow needs to be adjusted with the regulating valve after the flow meter, while the ball valve on the inlet remains full open. Mild steel pipes (galvanized pipes are not permitted) with a diameter not less than the connection size of the tank, should connect the unit to the system. Actual size of pipe is given for each Type of unit. It has to be installed as close as possible to the connection point, and as low as possible in the system.

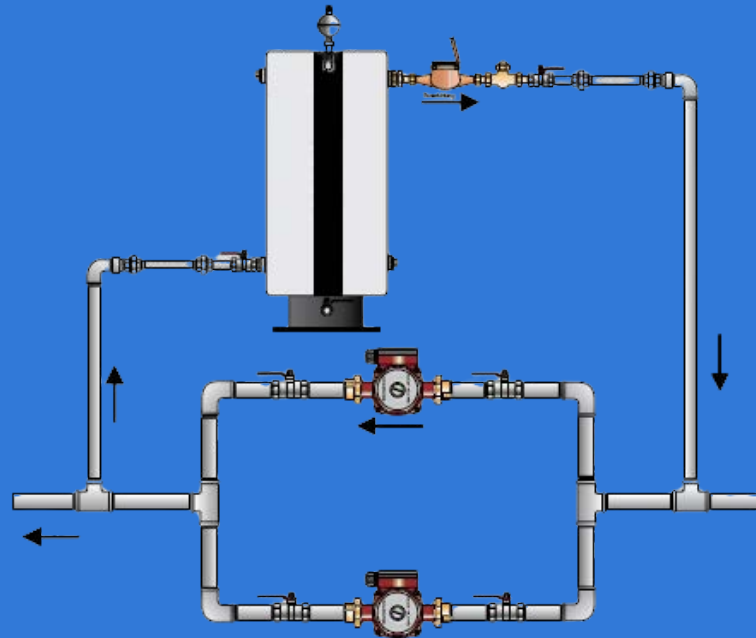

*\*For Type 100 to 260 there should be 1 meter clear space above the top of the unit for removal of anodes for maintenance purposes.  
Type 500 to 1000 should have 1 meter clearance in front of the tank to enable removal of anodes for maintenance.*

Unit	Height (mm)	Diameter (mm)
T100	1223	565
T260	1456	703
T500	1500	700
T800	2129	900
T1000	2596	984

# INSTALLATION OPTIONS

## SIDE STREAM INSTALLATION USING EXISTING PUMP

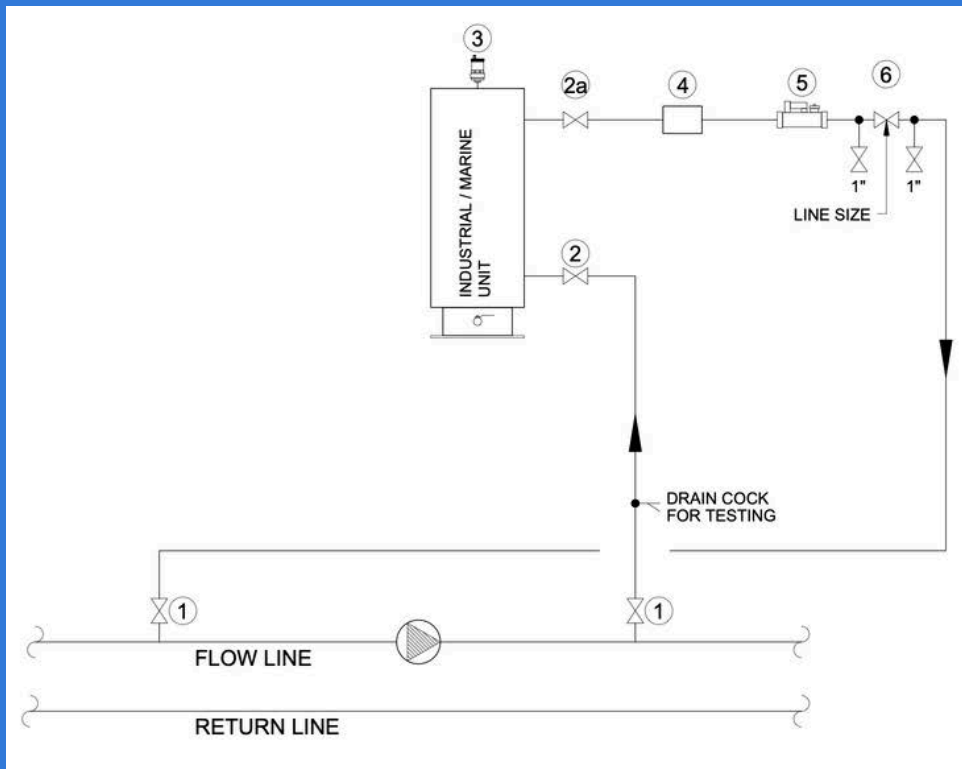

### KEY

- 1 CLIENT IV'S NOT SUPPLIED
- 2 DRAIN COCK LEVER IV
- 3 AIR VENT
- 4 MECHANICAL WATER METER
- 5 FLOW REGULATOR OR PICV
- 6 FLUSHING BY-PASS FOR RINSING DEVICE

## SIDE STREAM INSTALLATION USING OWN PUMP

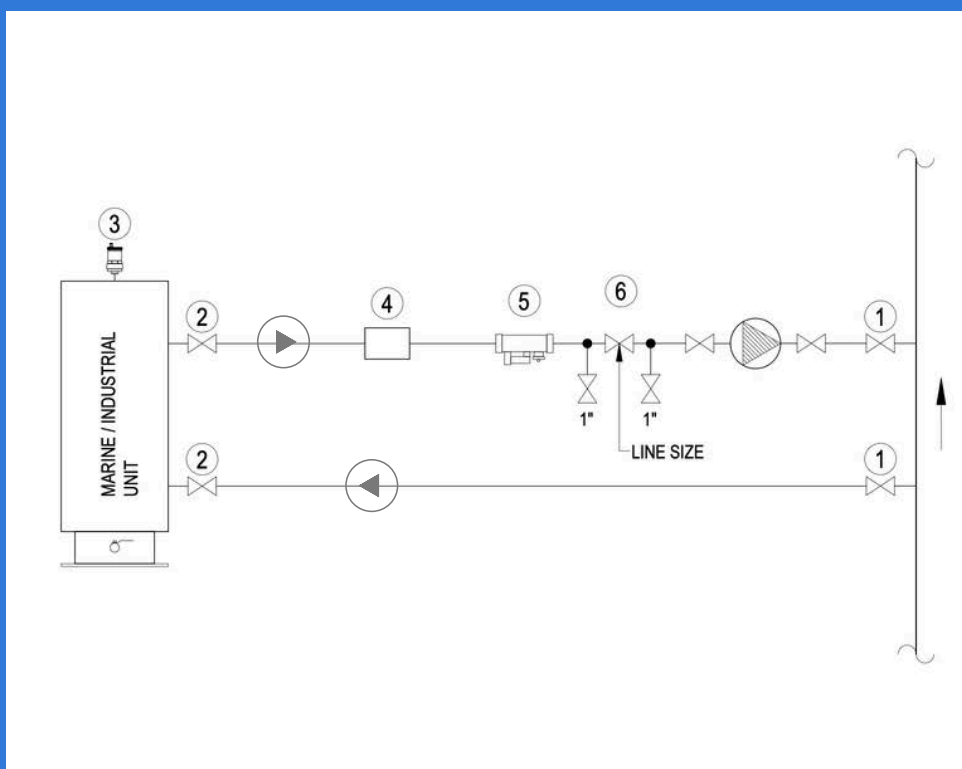

### KEY

- 1 CLIENT IV'S NOT SUPPLIED
- 2 DRAIN COCK LEVER IV
- 3 AIR VENT
- 4 MECHANICAL WATER METER
- 5 FLOW REGULATOR OR PICV
- 6 FLUSHING BY-PASS FOR RINSING DEVICE

*Note: Valve kit may alter depending on application*

# INSTALLATION

## STEAM APPLICATIONS

The unit should be located preferably as shown on the illustration. Both suction and discharge line are to be connected beneath the level of «low level alarm» to the hotwell. A separate circulation pump pushing water over the unit has to be installed with suction from the hotwell as low as possible.

The water flow needs to be adjusted with the regulating valve after the flow meter, while the ball valve on the inlet and outlet remains fully open.

Mild steel pipes (galvanized pipes are not permitted) with a diameter not less than 1" shall connect the unit to the system or as per the size specified for each type of unit

**We underline the importance that the unit should be located as low as possible in relation to the hotwell (preferably on the deck below the hotwell). The idea is to have the normal water level in the Hotwell above the top of the unit to get a net positive head and to avoid build-up of an air pocket in the unit.**

Should the top of the unit be approximately the same height as the normal water level in the Hotwell, a gooseneck should be made on the discharge line of the unit, to avoid build up of an air pocket in the unit.

The height of the gooseneck should be at least half a meter above the top of the unit.

Installation principle for hot well

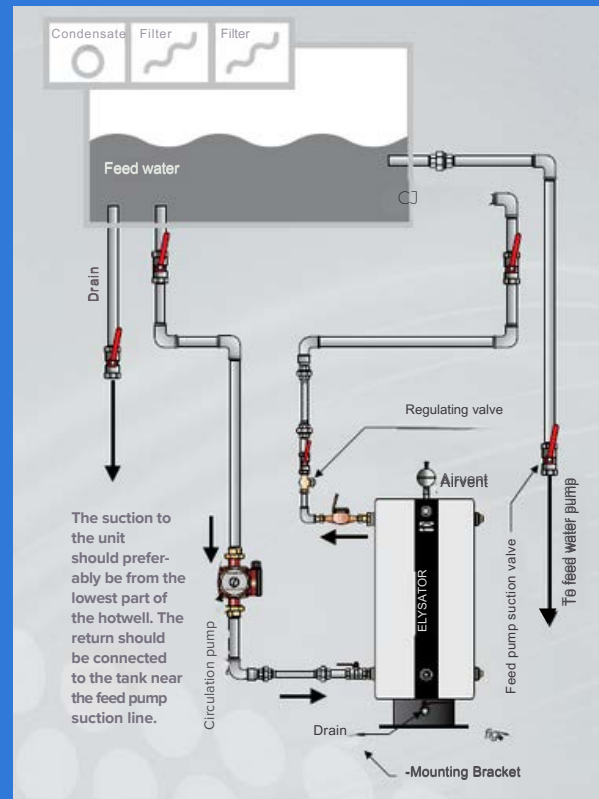

Also when starting the unit, the circulation pump should be started with both the inlet and discharge valves fully open, but the flow regulating valve should be fully closed. At this time ensure that the automatic air vent on top of the unit is open. When water starts to come out from the air vent (after all the air in the unit tank is vented), then slowly open the flow regulating valve till the desired (recommended) flow is achieved.

The hotwell temperature should be kept above 80 deg C to minimise the oxygen content.



# INSTALLATION

## INSTALLATION & COMMISSIONING INSTRUCTIONS

The unit can be either installed around the system pumps or as its own side stream with its own pump. If fitted around the pump our PICV will be required which will ensure a stable and controlled flow rate. Please see next page for instructions.

### PICV Selection Chart

Unit	Flow Rate	Connection Size	Pett PICV	Valve Setting
T100	20l/min	1"	92H. 1" with standard unions	4
T260	50l/min	1 ¼"	92H. 1¼" with standard unions	5.5
T500	100l/min	1 ½"	92H. 1½"	6
T800	160l/min	1 ½"	92H. 2"	6
T1000	200l/min	1 ½"	92H. 2"	8

The ideal installation is to install our unit and create a side stream installation using its own pump.

The T100 will require the pump and the PICV.

For the T260 upwards there will be no need for the PICV as the pumps listed on our selection chart are smart pumps which will be set to the required flow rate and the flow rate will then be maintained at times.

### Pump Selection Chart

Unit	Flow Rate	Connection Size	m <sup>3</sup> /hour	Pump
T100	20l/min	1"	1.2	UPS3 15-50/65
T260	50l/min	1 ¼"	3	Magna 3 25-80
T500	100l/min	1 ½"	6	Magna 3 25-80
T800	160l/min	1 ½"	9.6	Magna 3 40-80
T1000	200l/min	1 ½"	12	Magna 3 40-100

# INSTALLATION

## INSTALLATION & COMMISSIONING INSTRUCTIONS - PETTINAROLI VALVE

- Close the outlet valve.
- Keeping outlet closed whilst opening the inlet valve.
- Open the automatic air vent.
- Fill the unit once the automatic air vent has dispensed all of the air.
- Open the outlet valve so water flows through the Protector.
- Check the water meter is rotating.
- Set PIC valve as below:

Unit	Flow Rate	Connection Size	Pett PICV	Valve Setting
T100	20l/min	1"	92H. 1" with standard unions	4
T260	50l/min	1 ¼"	92H. 1 ¼" with standard unions	5.5
T500	100l/min	1 ½"	92H. 1 ½"	6
T800	160l/min	1 ½"	92H. 2"	6
T1000	200l/min	1 ½"	92H. 2"	8

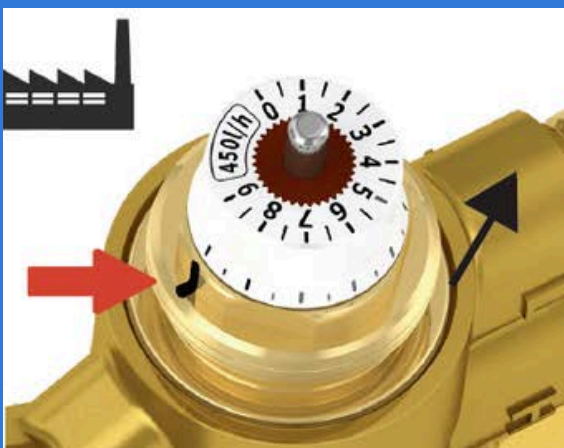

- Remove the handwheel. default setting: position 9



- Turn the selector to the target position to set the flow rate, the settings should be as the chart states.

Once you have set this up check the flow rate on the water meter corresponds to required settings on the PICV:

by reading the 0.01 cubic meter dial (=10 litre), which corresponds to litres per minute.

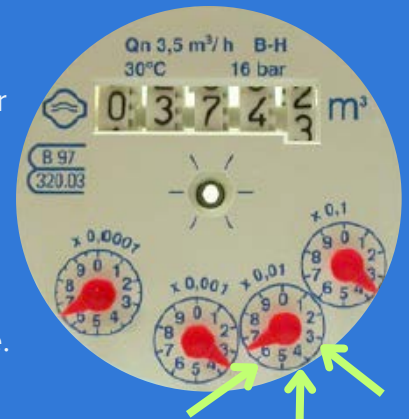

For example it should take 1 minute for the red arrow to read 2 if the setting on the PICV is 4 for 20 litres a minute, for the T100.



- Re-assemble the hand wheel cap with a ¾" turn to protect the spindle – do not turn more than this or you will push the spindle down and effect the flow rate.

# DATA & MEASUREMENTS

Model	Flow l/min	Volume m <sup>3</sup> LTHW	Volume m <sup>3</sup> CWS	Connection	Height mm	Diameter mm	Weight	Packaged Weight
T100	10-20	35	25	1"	1223	565	60	74
T260	20-50	70	50	1 1/4"	1456	703	250	285
T500	50-100	120	85	1 1/2"	1500	700	300	350
T800	80-160	220	155	1 1/2"	2129	900	400	450
T1000	100-200	300	220	1 1/2"	2596	984	400	450

**Max temp:** 150 C

**Max pressure:** 12 bar

**Test pressure:** 18.7 bar

*Note: Talk to us for systems that operate at higher pressures or higher temperatures - available on request*

# DATA & MEASUREMENTS

## T100

When mounting the unit, be sure to make sufficient space above the unit for maintenance

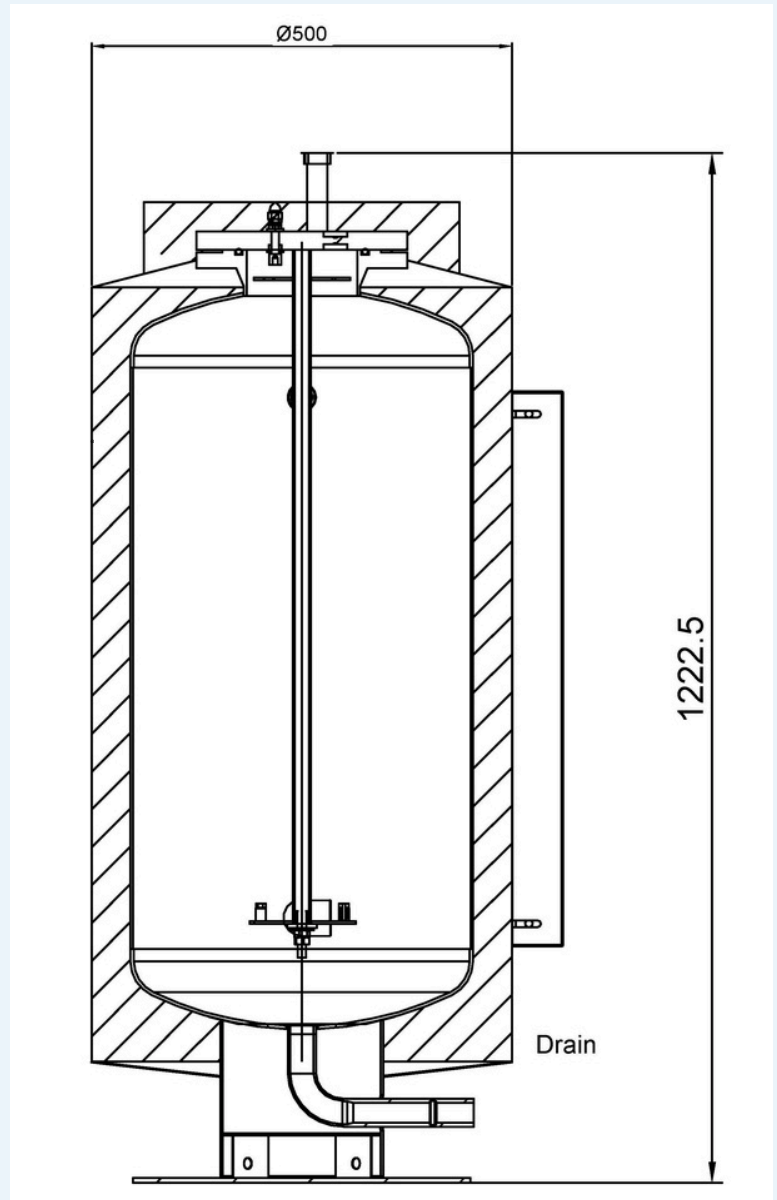
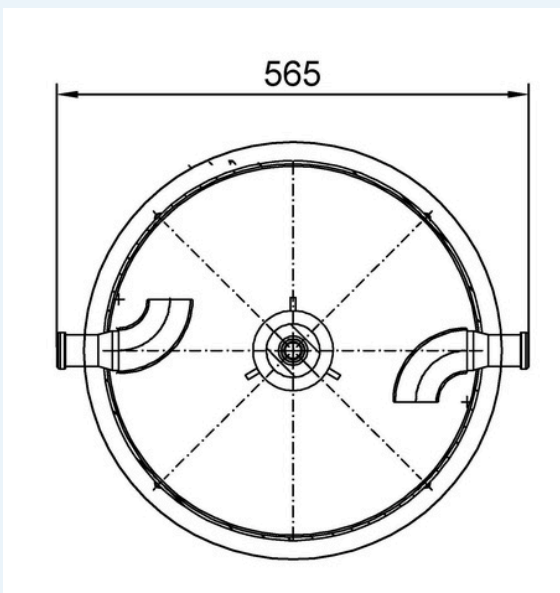

<b>Flowmeter</b>	1"
<b>Airvent</b>	1/2"
<b>Ballvalve in/out</b>	1"
<b>Reg.valve</b>	1"
<b>Drainvalve</b>	1 "
<b>Indicator</b>	0-100mA, analogue
<b>Anodes</b>	1 set (3pcs)

<b>Flow L/min</b>	10-20
<b>Connection</b>	1"
<b>Total Height</b>	1222.5 mm
<b>System volume up to</b>	35 m <sup>3</sup>
<b>Diameter</b>	500 mm
<b>Weight</b>	60 kg
<b>Freight weight</b>	74 kg

# DATA & MEASUREMENTS

## T260

Both inlet and outlet are placed 90 degrees to the right from the front panel.

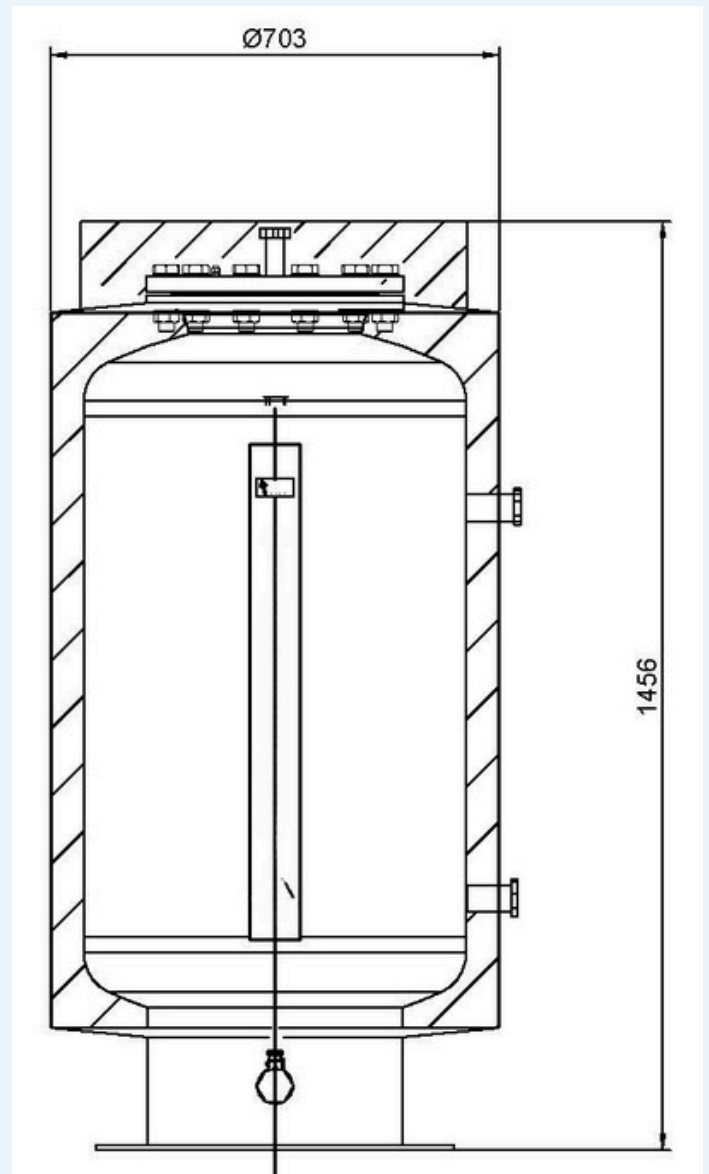
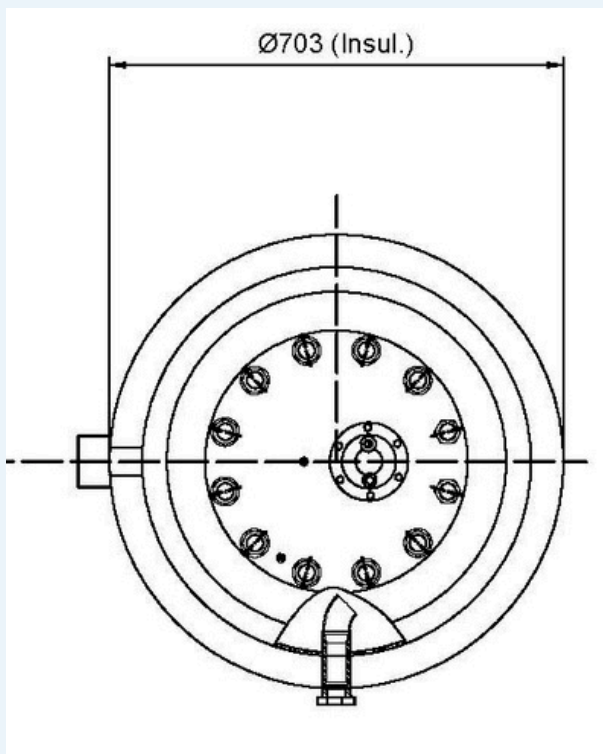

<b>Flowmeter</b>	1 ¼"
<b>Airvent</b>	1/2"
<b>Ballvalve in/out</b>	1 ¼"
<b>Reg.valve</b>	1 ¼"
<b>Drainvalve</b>	1 ½"
<b>Indicator</b>	0-100mA, analogue
<b>Anodes</b>	1 set (6pcs)

<b>Flow L/min</b>	20-50
<b>Connection</b>	1 ¼"
<b>Total Height</b>	1456 mm
<b>System volume up to</b>	70 m <sup>3</sup>
<b>Diameter</b>	703 mm
<b>Weight</b>	250 kg
<b>Freight weight</b>	285 kg

# DATA & MEASUREMENTS

## T500

Both inlet and outlet are placed 90 degrees to the right from the front panel.

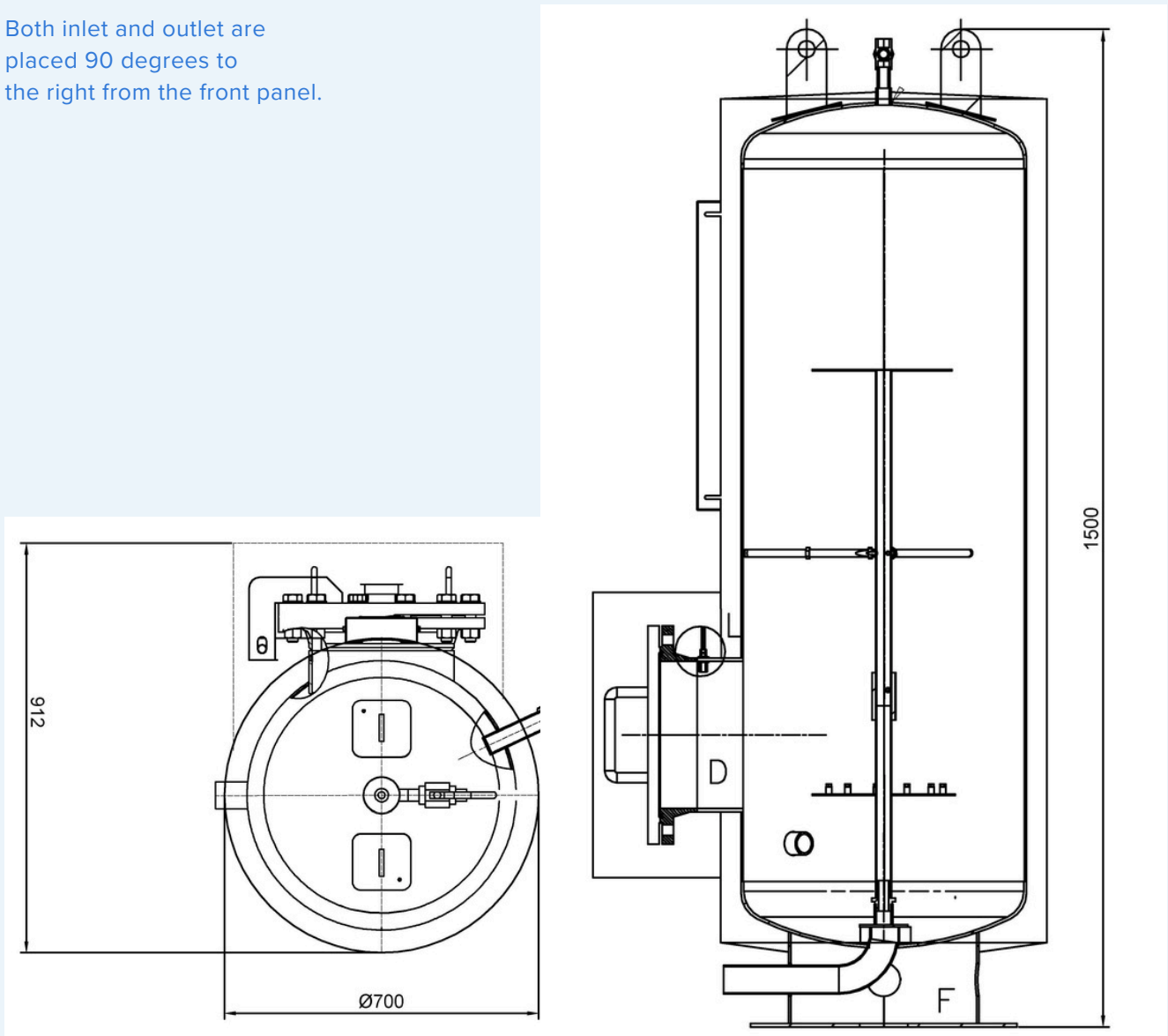

<b>Flowmeter</b>	1 ½"	<b>Flow L/min</b>	50-100
<b>Airvent</b>	3/4"	<b>Connection</b>	1 ½"
<b>Ballvalve in/out</b>	1 ½"	<b>Total Height</b>	1500 mm
<b>Reg.valve</b>	1 ½"	<b>System volume up to</b>	120 m <sup>3</sup>
<b>Drainvalve</b>	1 ½"	<b>Diameter</b>	700 mm
<b>Indicator</b>	0-100mA, analogue	<b>Weight</b>	300 kg
<b>Anodes</b>	1 set (6pcs)	<b>Freight weight</b>	350 kg

# DATA & MEASUREMENTS

## T800

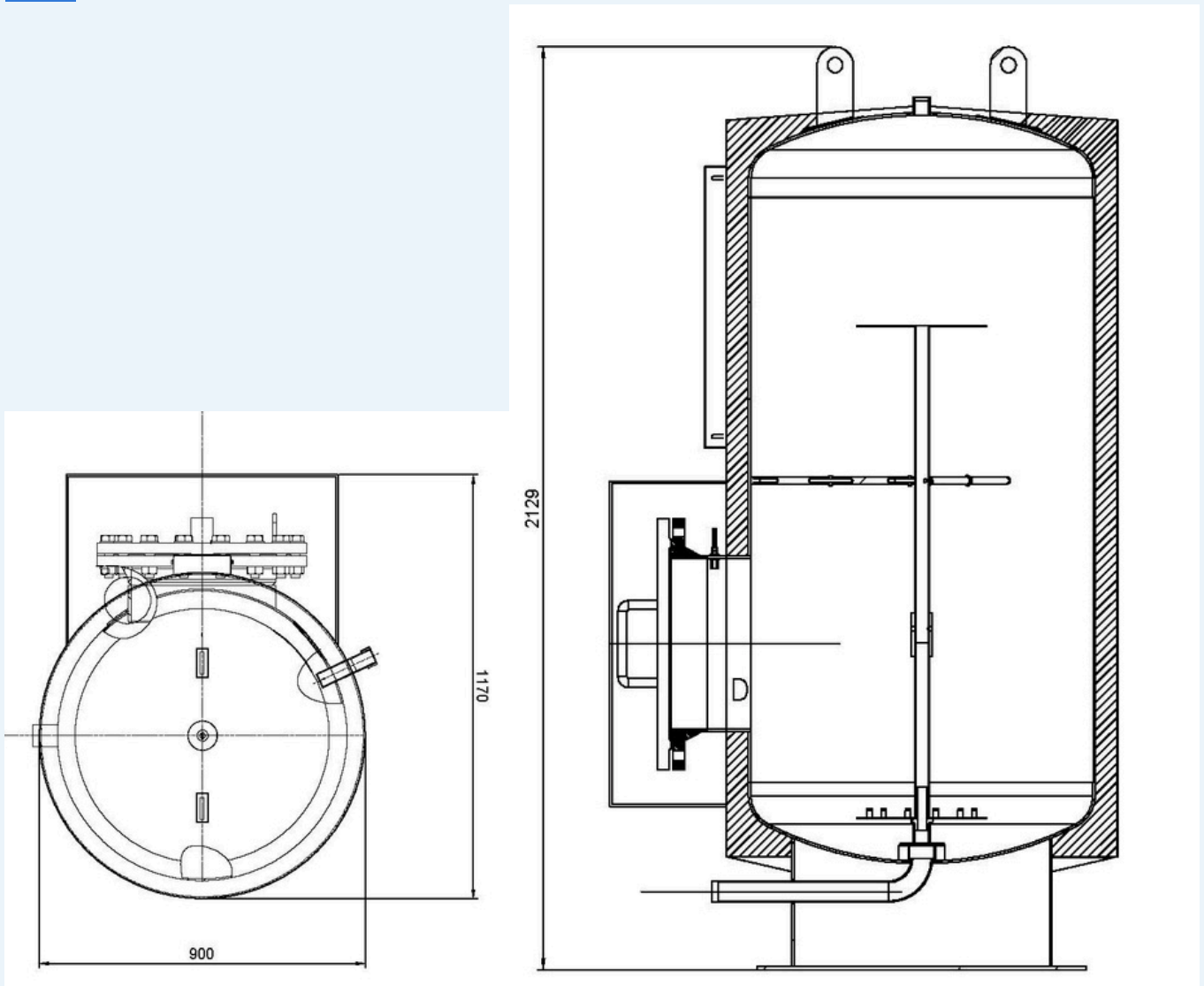

## T800

<b>Flowmeter</b>	1 ½"
<b>Airvent</b>	3/4"
<b>Ballvalve in/out</b>	1 ½"
<b>Reg.valve</b>	1 ½"
<b>Drainvalve</b>	1 ½"
<b>Indicator</b>	0-100mA, analogue
<b>Anodes</b>	1 set (9pcs)

## T800

<b>Flow L/min</b>	80-160
<b>Connection</b>	1 ½"
<b>Total Height</b>	2129 mm
<b>System volume up to</b>	220 m <sup>3</sup>
<b>Diameter</b>	900 mm
<b>Weight</b>	400 kg
<b>Freight weight</b>	450 kg

# DATA & MEASUREMENTS

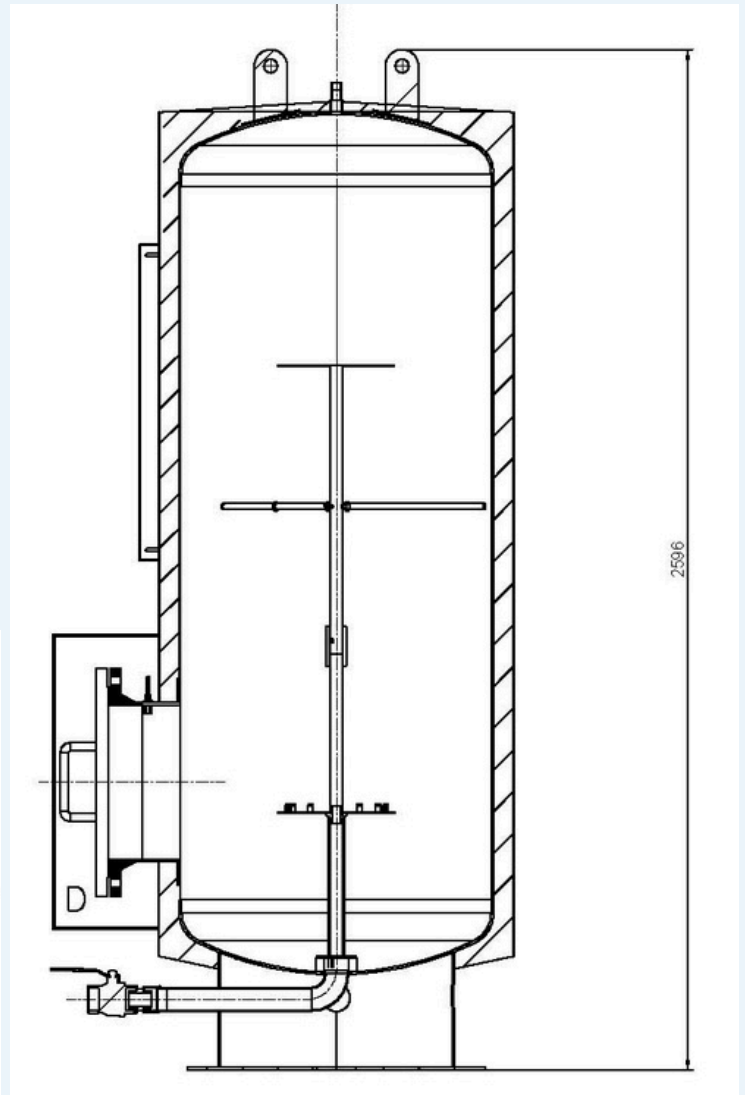
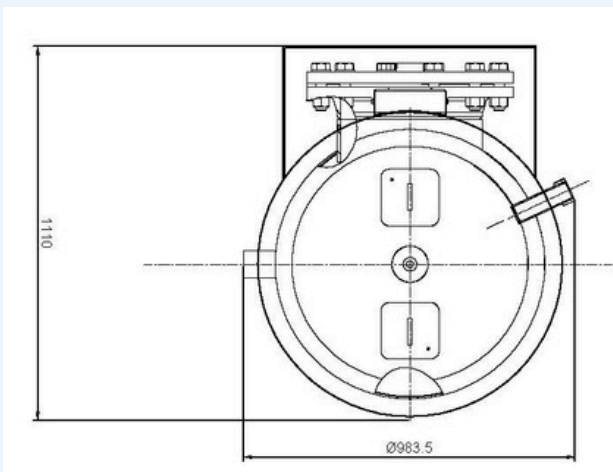

## T1000

<b>Flowmeter</b>	1 ½"
<b>Airvent</b>	3/4"
<b>Ballvalve in/out</b>	1 ½"
<b>Reg.valve</b>	1 ½"
<b>Drainvalve</b>	1 ½"
<b>Indicator</b>	0-100mA, analogue
<b>Anodes</b>	1 set (12pcs)

## T1000

<b>Flow L/min</b>	100-200
<b>Connection</b>	1 ½"
<b>Total Height</b>	2596 mm
<b>System volume up to</b>	300 m <sup>3</sup>
<b>Diameter</b>	983.5mm
<b>Weight</b>	400 kg
<b>Freight weight</b>	450 kg



# MAINTENANCE

## ANODE MOUNTING

**T500/800/1000:**

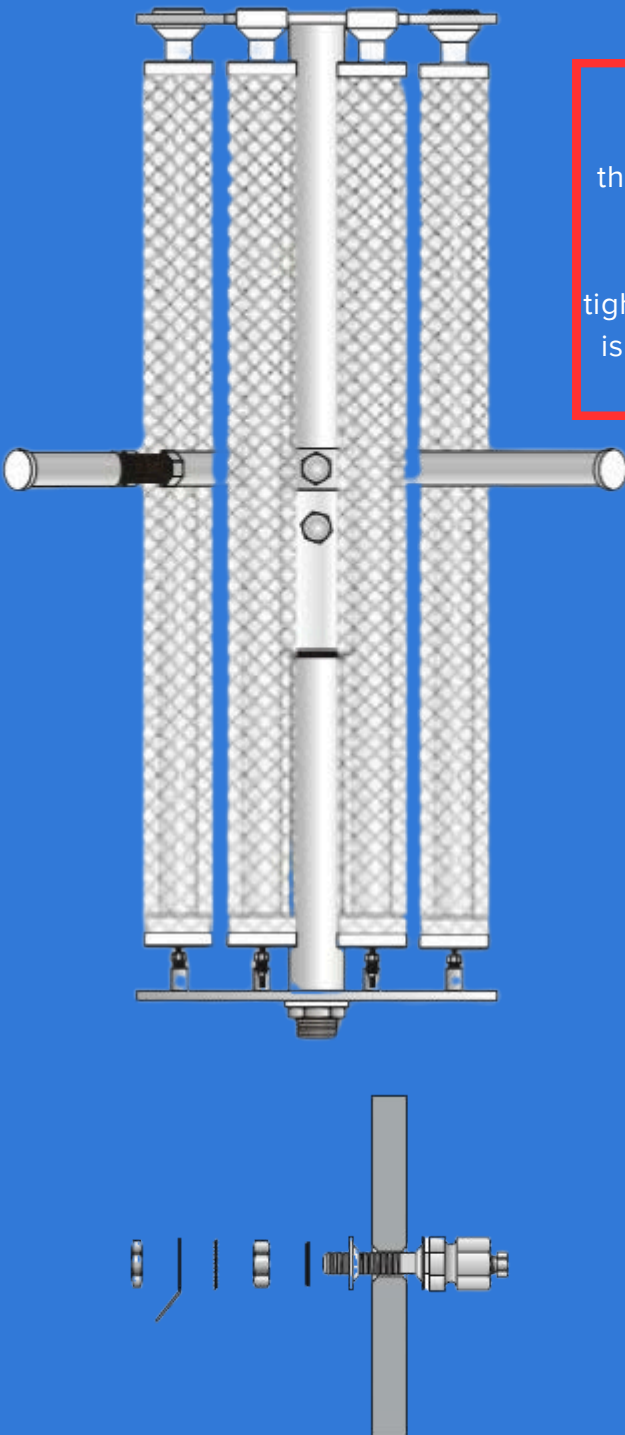

Caution!  
Do not tighten  
the anode isolation bolt  
too hard after  
maintenance. When  
tightening too hard, there  
is a risk of cracking the  
teflon washer.

**T260:**

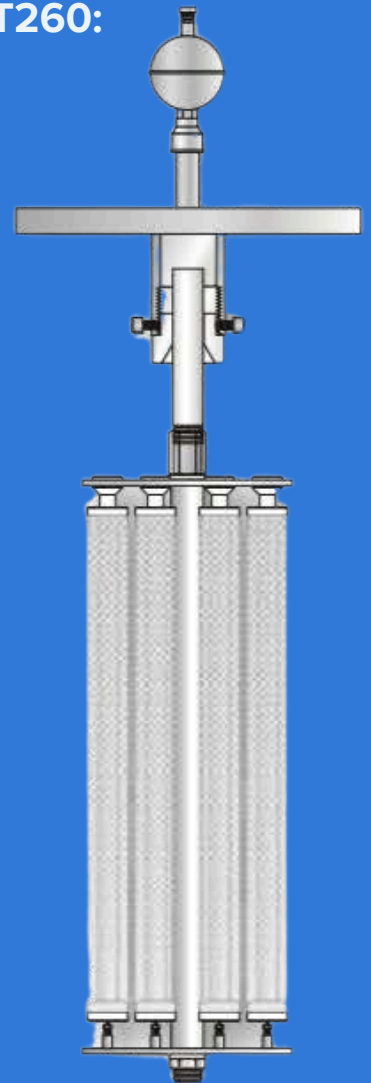

**T100:**



# MAINTENANCE

## CLEANING THE ANODES

When the Amp Meter is in the red (to left), the anode might be corroded away or an insulating layer is covering the anode (or the entire water system has been completely passivated), so the galvanic current is minimal.

**Service note:** the water meter readings are used to record the volume passed between services so you can then calculate from the l/min how many hours the unit has been in operation. For example  $100m^3$  at 10 l/min = 166.66 hrs of operation

## STEP BY STEP

1. On a heating system let the unit cool down before carrying out a service
2. Close the inlet and outlet valves.
3. Release the magnet.
4. Partially open the drain valve and then remove the AAV or open the anti-vacuum relief valve on the T500, T800 and T1000 units, now fully open the drain valve to hard flush the collected debris.
5. Remove the insulating cover for access to manway / flange. Up to and including the 260 model the flange is on the top, for the T500, T800 and T1000 the flange behind the front manway.
6. Release the anode cables gently.
7. Up to and including the T260 you only need to partially drain the tank to replace the anodes, on the T500 and upwards the tank will need to be fully drained.
8. Up to and including the T100 unbolt and lift off the flange and lift clear with the anodes in place.
9. Release the anodes from the flange, making sure you hold the anode insulation bolt in place with a spanner whilst undoing the anode.
10. On the T260 unbolt and remove the top flange and then undo the central carousel retaining rod and then lift the carousel clear with the anodes attached.
11. On the T500 upwards the anodes are reached via the manway and can be released one at a time.
12. Clean the anode(s) by means of using a hose or jet washer.
13. If there is compacted debris between the anode and the mesh, the anode will need to be replaced.
14. When mounting back in place a new or cleaned anode, use always-correct 10 mm and 17 mm spanner, and keep attention to the insulated bolt through the flange, so as to not overtighten the teflon seal.
15. Clean the unit internally with cold water (no chemicals).
16. The unit should then be reassembled and adjusted to the correct flow.



typical water meter

# MAINTENANCE

## REPLACING THE ANODE

If the indicator of the instrument is completely in the red area, showing "service", fill the unit with fresh water to check if the display is changing. This way it is possible to test the function of the anode without opening the unit. If the indicator stays in the red area, the unit should be opened to check or replace the anode.

If there is no indication on the Amp Meter, the unit is not working. If you have no indication after changing the anodes, check if:

- The unit has been refilled with water
- The white isolation washers are both in place (no shortcut between anode and cathode)
- The electrical wiring has been reinstalled properly
- The instrument is not working (use an external mA-meter for testing)

### TOOLS:

- Isolating nut dry side 13 mm spanner
- Isolating bolt wet side 17 mm spanner
- Anode bolt 10 mm spanner
- Flange cover nuts 19 mm spanner

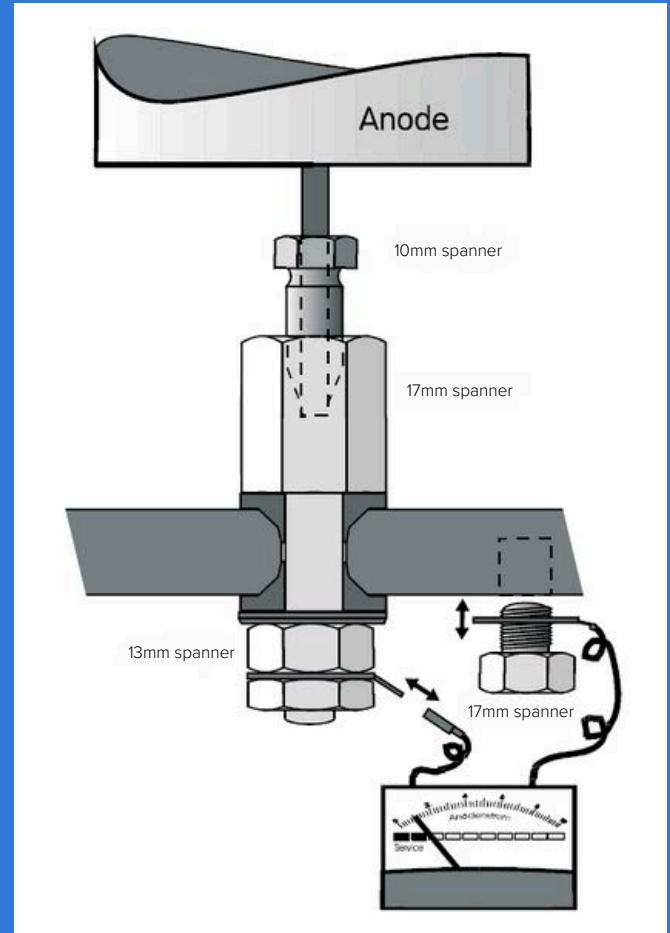

Unit	Bolts	Spanner / Socket Size	Torque Value
100L	M16	24mm	570 Nm
260L	M24	36mm	570 Nm
500L	M24	36mm	570 Nm
800L	M27	41mm	840 Nm
1000L	M27	41mm	840 Nm

# MAINTENANCE

## IMAGES OF SERVICING

All inspection, cleaning + replacement is carried out via the manway / flange door, on the T500/800/1000

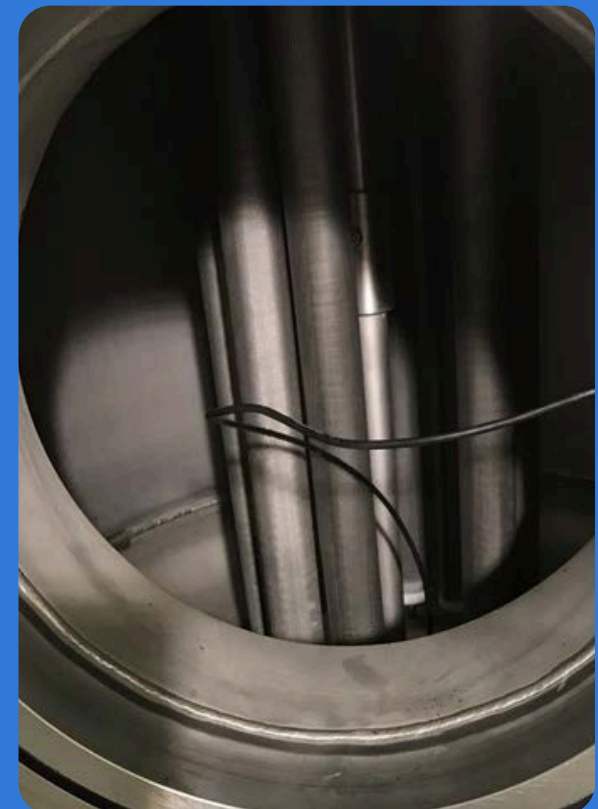

# ACCESSORIES

Part No.	Description
<b>Complete Units</b>	
100994	Marine T100
100507	Marine T260
100413	Marine T500
100404	Marine T800
100407	Marine T1000
<b>Anodes</b>	
100384	T100 Spare Anodes, 3pcs
100384	T260 Spare Anodes, 6pcs
100385	T500 Spare Anodes, 6pcs
100386	T800 Spare Anodes, 9pcs
100225	T1000 Spare Anodes, 12pcs
LP1026	T100/260 anodes for systems operating above 80°C
LP5810	T500/800/1000 anodes for systems operating above 80°C
<b>Gaskets</b>	
23563	T100 Gaskets
23562	T260 Gaskets
25F300	T500 Gaskets
25F400	T800/1000 Gaskets
<b>PICV</b>	
PEB92H.08	T100 PICV / 92H 1" with standard unions
PEB92H.10	T260 PICV / 92H. 1 ¼" with standard unions
PEB92H.12	T500 PICV / 92H. 1 1/2"
PEB92H.16	T800 PICV / 92H. 2"
PEB92H.16	T1000 PICV / 92H. 2"
<b>Spare Parts</b>	
CASCM0015	T100/260 - AIR VENT CALLEFFI DISCAL
501500	T500/800/1000 - AIR VENT CALLEFFI MAXCAL
100078	ANALOG INDICATOR

# PROJECT PICTURES

**240 Blackfriars**

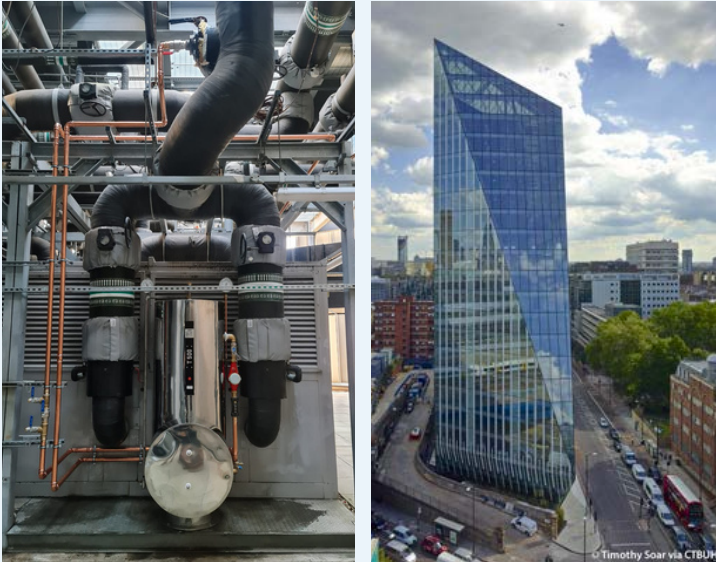

**Bunhill Energy Centre**



**Swaffham Prior**



**6 Bevis Marks**



**Viking Energy Network**





# Environmental Culture Change

*be a part of it*

clean | protect | prevent





Founded in 1992, IWTM have been working with chemical free water treatment using electrochemistry for over 30 years and have offices in Norway, UK, Finland, Sweden, Canada, USA and a worldwide presence in the Marine sector.

We have developed models specifically suited to the higher demands of the marine industry operating at higher pressures and higher temperatures.

Which makes these units particularly suitable for land based projects, which require either high temperature of high pressure

The marine products are provided worldwide on the world's largest cruise ships working with the leading operators in this sector.

Having secured DNV approval in 2003, we are still the only chemical free water treatment manufacturer to have this certification and approval. DNV is a globally leading quality assurance and risk management company operating in more than 100 countries.

The IWTM Protector™ is our most recently developed product. The Protector range is now available to our land-based customers.

Version 1: July 2024

*In line with continued product development we reserve the right to make any changes to this document without any given notice.*

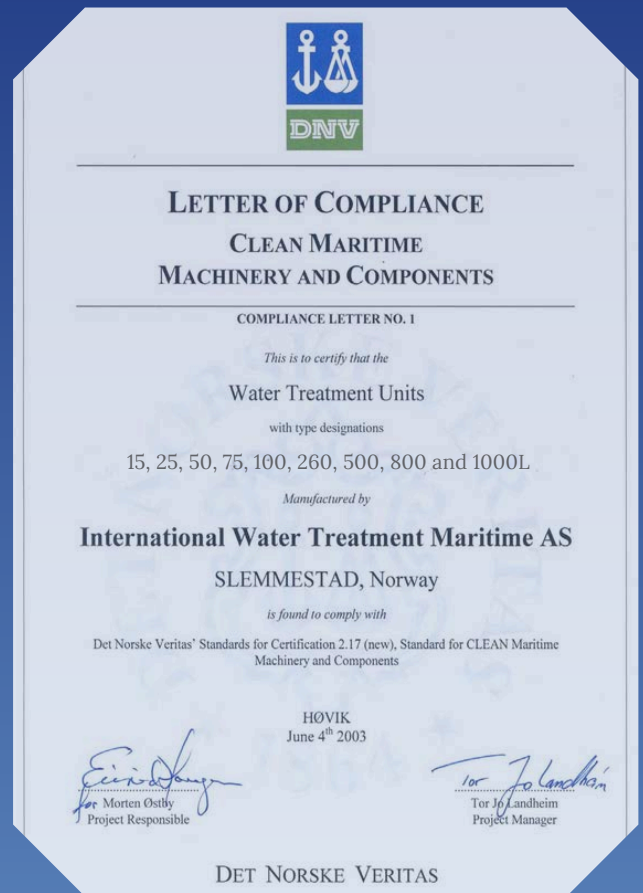

SUTTON BUSINESS CENTRE  
RESTMOR WAY  
WALLINGTON SM6 7AH

WWW.IWTM-UK.COM  
T: +44 208 255 2903  
E: INFO@IWTM-UK.COM